

# Neue Materialmodelle für Composites in LS-DYNA

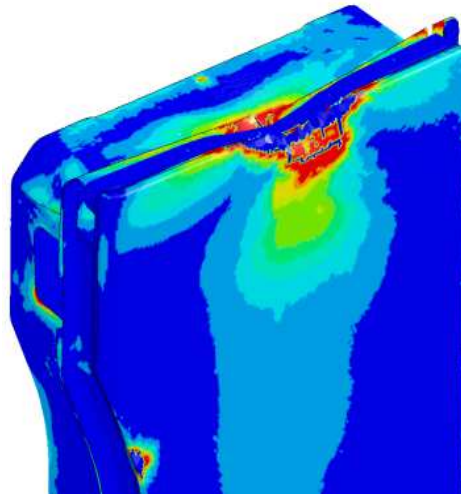

Stefan Hartmann  
DYNAmore GmbH, Stuttgart

**Infotag:**  
Composite Berechnung mit LS-DYNA, 17. April 2013, Stuttgart

# Outline

- Introduction

- failure mechanisms / modeling possibilities / layer definition / remarks

- Material models for intralaminar failure

- \*MAT\_LAMINATED\_FRACTURE\_DAIMLER\_PINHO (\*MAT\_261)
  - \*MAT\_LAMINATED\_FRACTURE\_DAIMLER\_CAMANHO (\*MAT\_262)
  - summary and comparison

- Preliminary results

- three point bending of flat specimen / three point bending of a hat profile / shear specimen / drop tower test

- Summary and Outlook



## failure mechanisms in fiber reinforced composites

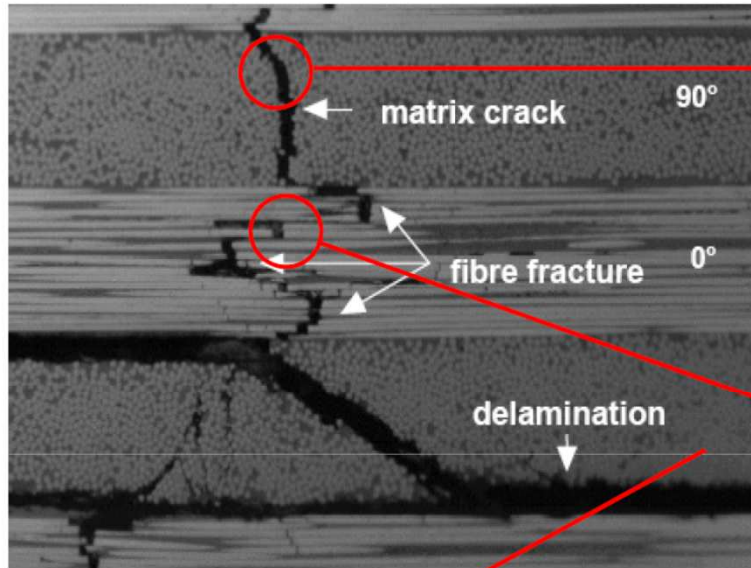

R Olson,  
Imperial College  
London

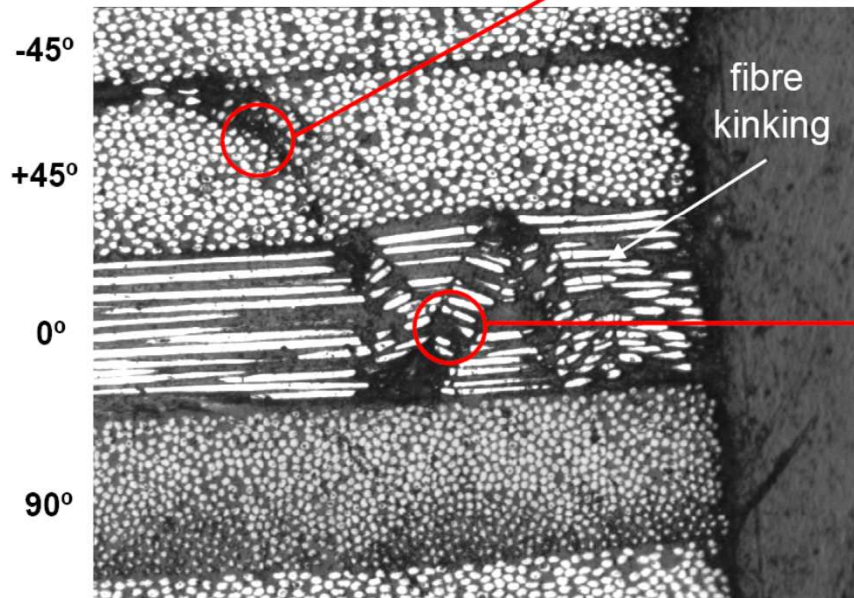

PP Camanho,  
PhD thesis, Imperial College London

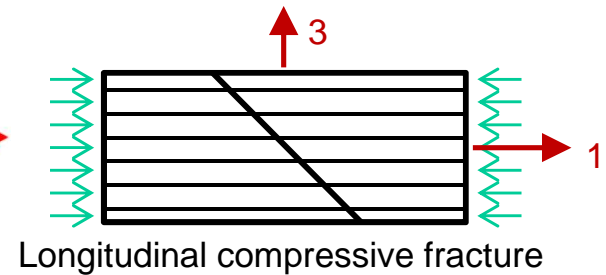
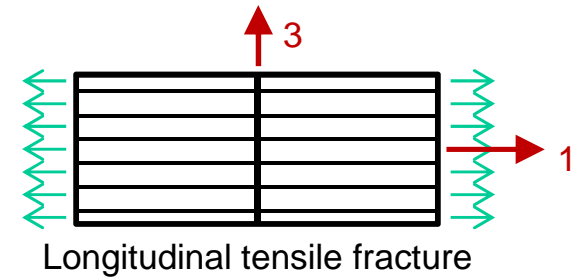
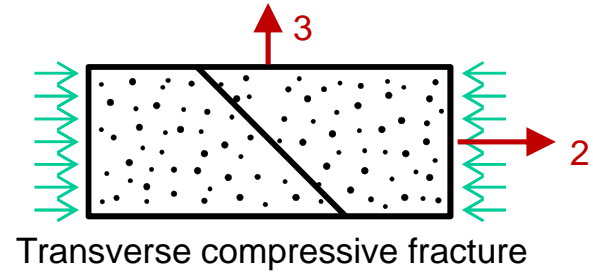
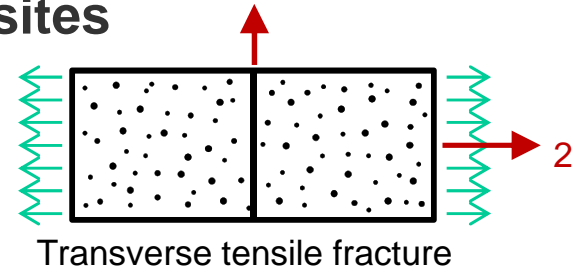

## modeling possibilities

### ■ intralaminar

- element: layered (thin/thick) shells  
one solid element per ply
- material: plasticity / damage models

### layered thin shell elements

- + numerical „cheap“ (thickness does not influence the critical time step size)
- + combination of single layers to sub-laminates
- no stresses in thickness dir. (no delamination)

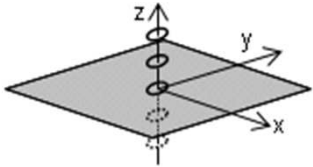

### layered thick shell elements

- + 3D stress state
- + combination of single layers to sub-laminates
- thickness influences the critical time step size

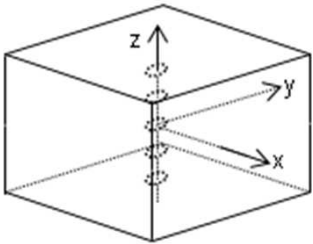

### solid elements

- + 3D stress state
- one element for every single layer (no layering)  
→ numerical „expensive“

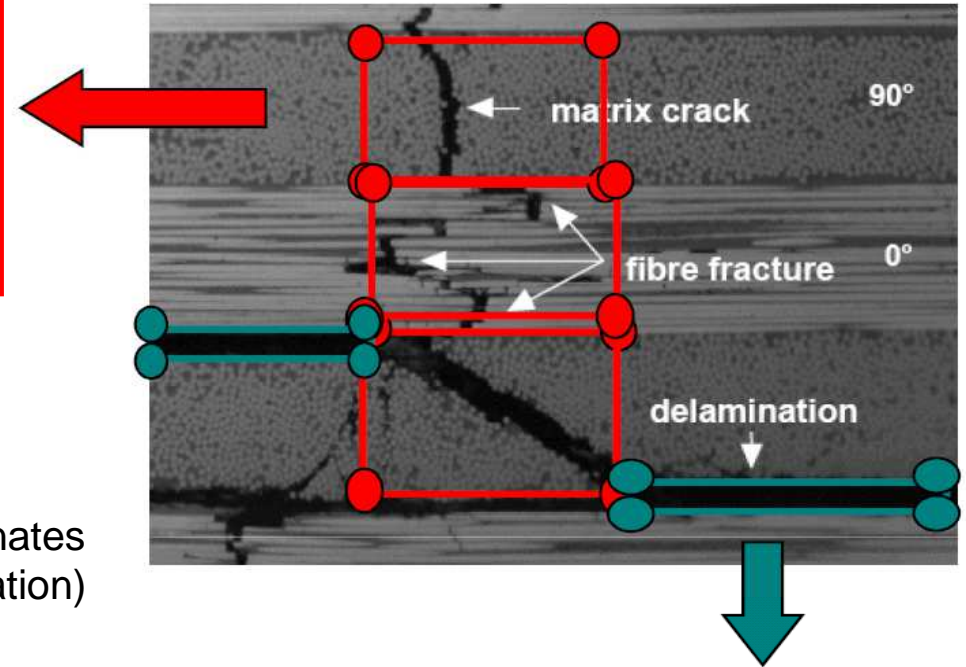
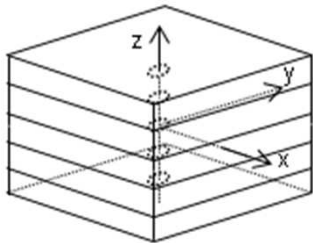

### ■ interlaminar (delamination)

- cohesive elements
- tiebreak contacts

stacked shells

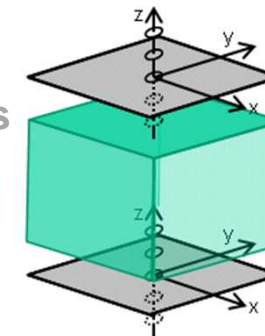

layered thin shell element

cohesive element

layered thin shell element



## layered thin shell definition with \*PART\_COMPOSITE(\_TSHELL)

- no \*SECTION\_SHELL-keyword card needed
- different material models allowed

### \*PART\_COMPOSITE(\_TSHELL)

	1	2	3	4	5	6	7	8
Card 1	PID	ELFORM	SHRF	NLOC	MAREA	HGID	ADOPT	
	28	2	0.0	0.0				
Card 2	MID1	THICK1	BETA1		MID2	THICK2	BETA2	
	1	0.2	0.0		2	0.4	45.0	
Card 3	MID3	THICK3	BETA3		MID4	THICK4	BETA4	
	3	0.2	90.0					
...								

add as many cards are necessary to define the whole layup (define two layers per card)

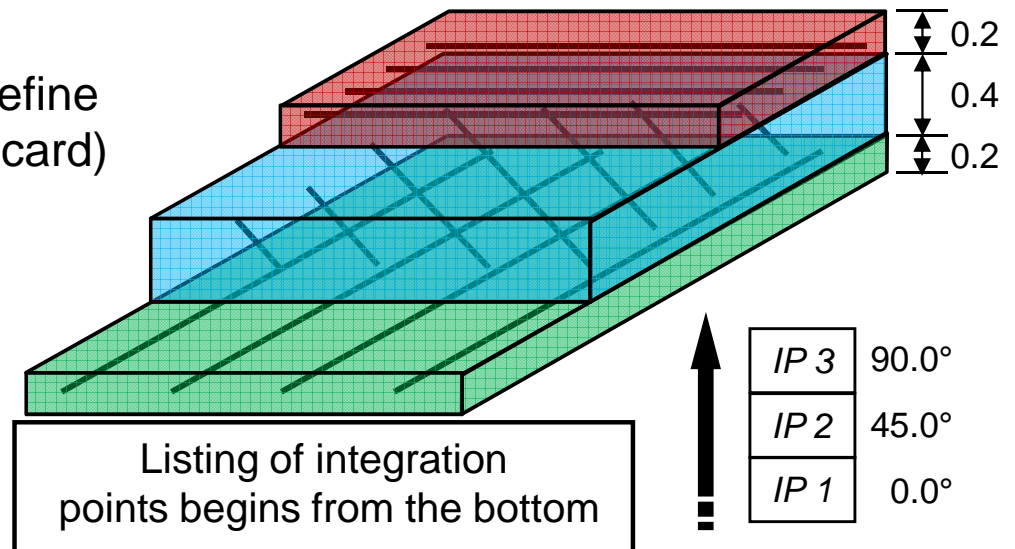



## layered thin shell definition with \*PART\_COMPOSITE(\_TSHELL)

- need \*SECTION\_(T)SHELL-keyword card to define ELFORM
- different material models allowed

### \*ELEMENT\_(T)SHELL\_COMPOSITE

	1	2	3	4	5	6	7	8	9	10
Card 1	EID	PID	N1	N2	N3	N4	N5	N6	N7	N8
	1	2	3	4	5	6	7	8		
Card 2	MID1	THICK1	BETA1		MID2	THICK2	BETA2			
	1	0.2	0.0		2	0.4	45.0			
Card 3	MID3	THICK3	BETA3		MID4	THICK4	BETA4			
	3	0.2	90.0							
...										

add as many cards are necessary to define the whole layup (define two layers per card)

Now it is possible to define different „Lay-ups“ within the same PART

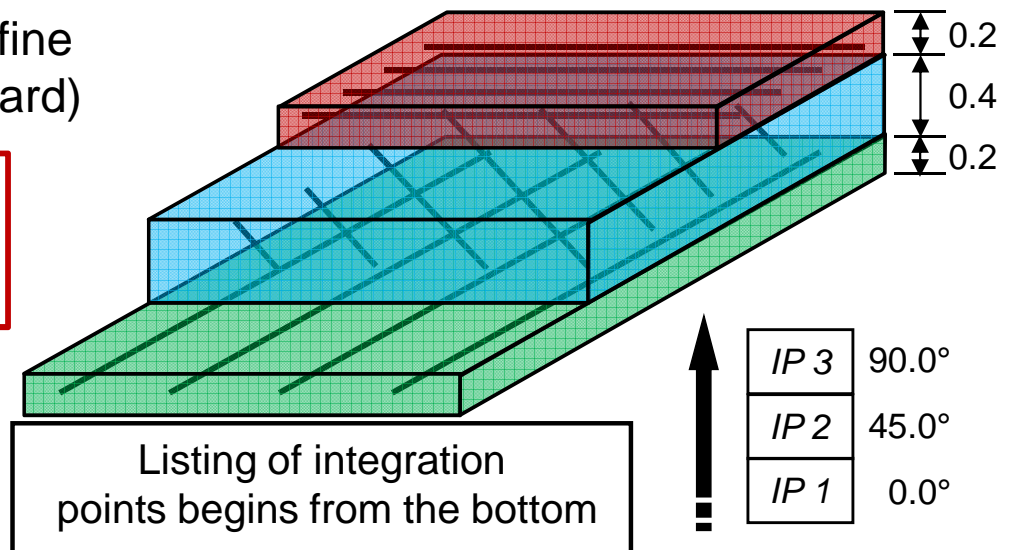



## Outlook: ply based modeling with \*ELEMENT\_(T)SHELL\_COMPOSITE8

- definition of a Ply ID will allow an easier post-processing
- new LS-PrePost versions will support ply based modeling
- separate binary file for post-processing of composite parts

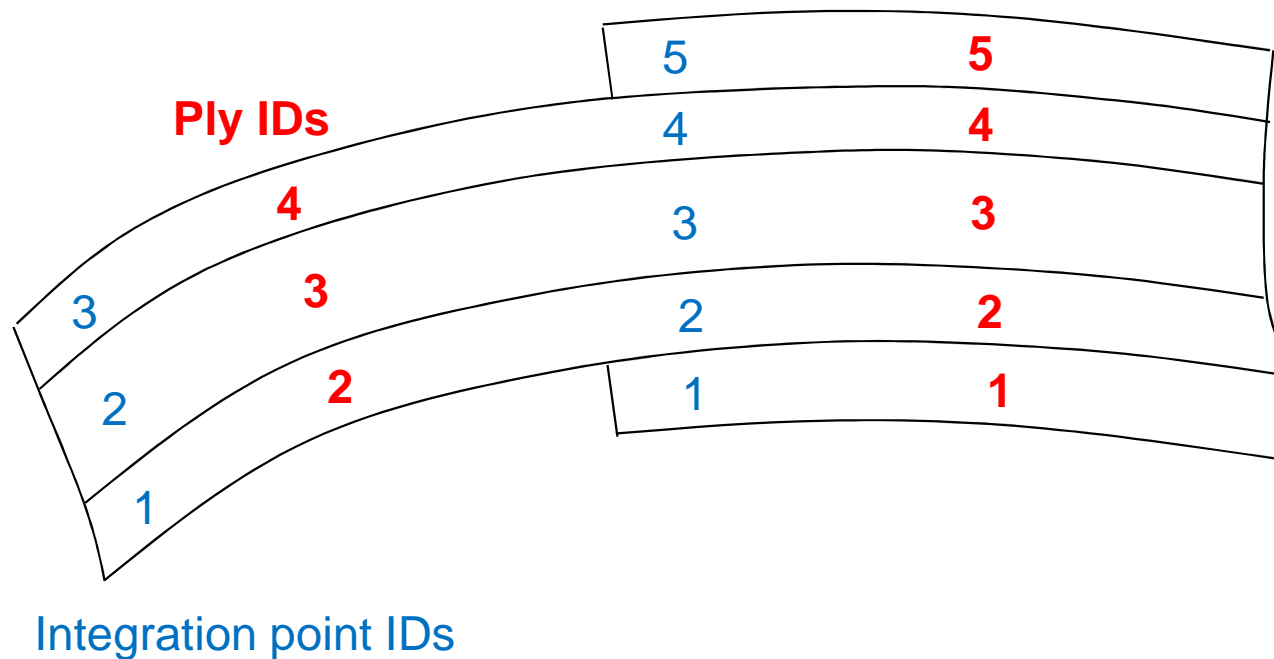



## some remarks

- extra history variables

many composite material models have extra history variables that help to track modes of failure in each integration point (see material documentation in the LS-DYNA Keyword User's Manual for details). A list of history variables is given here:

<http://www.dynasupport.com/howtos/material/history-variables>

NEIPS (shells) or NEIPH (solids) in \*DATABASE\_EXTENT\_BINARY should be set to the number of extra history variables needed. For example, if you want to track the damage parameters (6 extra history variables) in \*MAT\_054, set NEIPS=6.

- output of stresses and strains in the local material coordinate system (IPs)  
→ set CMPFLG=1 in \*DATABASE\_EXTENT\_BINARY

	binout	d3plot	
		global	local *)
CMPLFG=0	Element KOS	Global KOS	Element KOS
CMPFLG=1	Material KOS	Material KOS	undefined

\*) Formerly LSPP did not know about INN (information not written to d3plot), so transformation from Global KOS → Element KOS might not be correct.

This is fixed with LS-DYNA Version R7 and later and newer LSPP versions (4.1).





available  
since R7.0

**\*MAT\_261: [1]**  
**\*MAT\_LAMINATED\_FRACTURE\_**  
**DAIMLER\_PINHO**

**\*MAT\_262: [2]**  
**\*MAT\_LAMINATED\_FRACTURE\_**  
**DAIMLER\_CAMANHO**

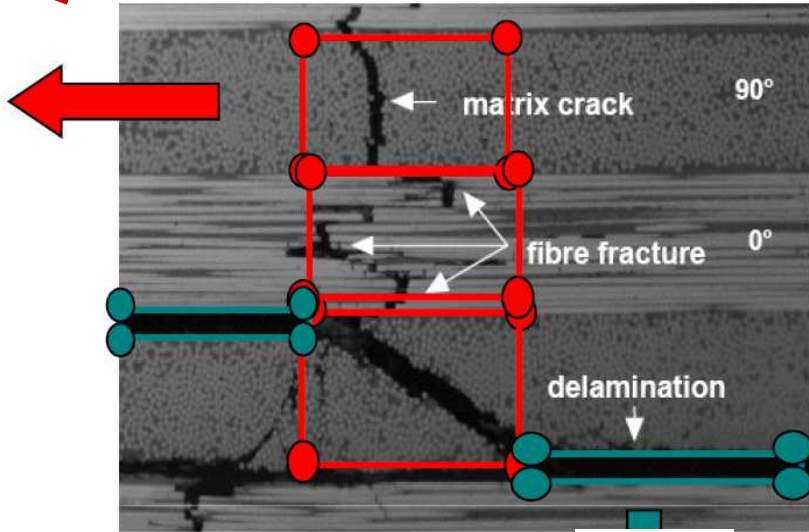

(Development together with Daimler AG)

[1] Pinho, S.T., Iannucci, L.; Robinson, P.: “Physically-based failure models and criteria for laminated fiber-reinforced composites with emphasis on fiber kinking: Part I – Development & Part II – FE implementation”, Composites: Part A 37, 2006

[2] Maimí, P., Camanho, P.P., Mayugo, J.A., Dávila, D.G.: “A continuum damage model for composite laminates: Part I – Constitutive model & Part II – Computational implementation and validation”, Mechanics of Materials 39, 2007

\*MAT\_261 (\*MAT\_LAMINATED\_FRACTURE\_DAIMLER\_PINHO):

- constitutive law

$$\hat{\sigma} = (1 - d) \tilde{\sigma}$$

4 damage parameter

$$d_{mat}; d_{mac}; d_{kink}; d_a$$

- 4 failure criteria

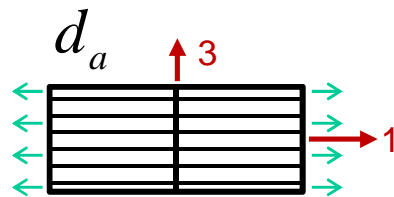

a) Longitudinal tensile fracture

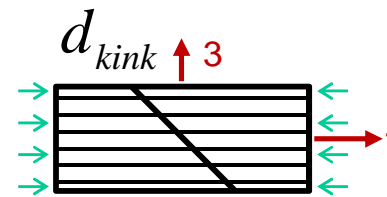

b) Longitudinal compressive fracture

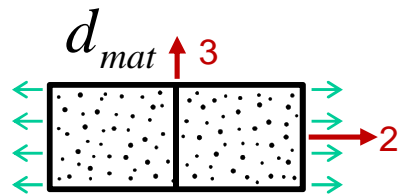

c) Transverse fracture with  $\alpha=0^\circ$

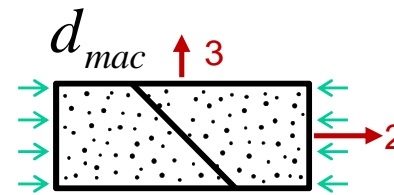

d) Transverse fracture with  $\alpha=53^\circ$

## \*MAT\_261 (\*MAT\_LAMINATED\_FRACTURE\_DAIMLER\_PINHO):

- physically based failure criteria
- continuum damage model

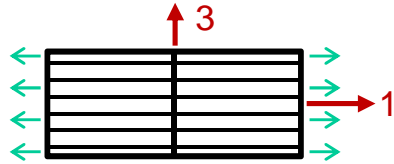

a) Tensile fibre mode  
(maximum stress)

$$e_f^2 = \left( \frac{\tilde{\sigma}_{11}}{X_T} \right)^2 - 1$$

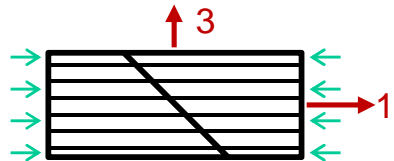

b) Compressive fibre mode  
(3D-kinking model)

$$e_c^2 = \left( \frac{\tau_T}{S_T - \mu_T \sigma_n} \right)^2 + \left( \frac{\tau_L}{S_L - \mu_L \sigma_n} \right)^2 - 1 \quad (\sigma_n \leq 0)$$

$$e_c^2 = \left( \frac{\sigma_n}{Y_T} \right)^2 + \left( \frac{\tau_L}{S_L} \right)^2 + \left( \frac{\tau_T}{S_T} \right)^2 - 1 \quad (\sigma_n > 0)$$

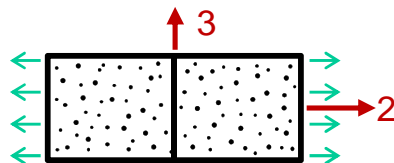

c) Tensile matrix mode  
(transf. fracture plane)

$$e_m^2 = \left( \frac{\sigma_n}{Y_T} \right)^2 + \left( \frac{\tau_T}{S_T} \right)^2 + \left( \frac{\tau_L}{S_L} \right)^2 - 1$$

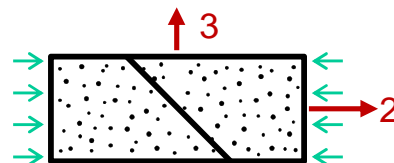

d) Compressive matrix mode  
(transf. fracture plane)

$$e_d^2 = \left( \frac{\tau_T}{S_T - \mu_T \sigma_n} \right)^2 + \left( \frac{\tau_L}{S_L - \mu_L \sigma_n} \right)^2 - 1$$

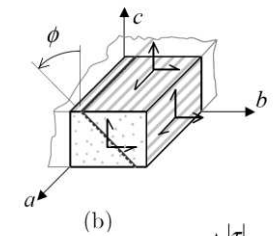
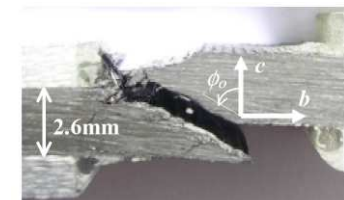
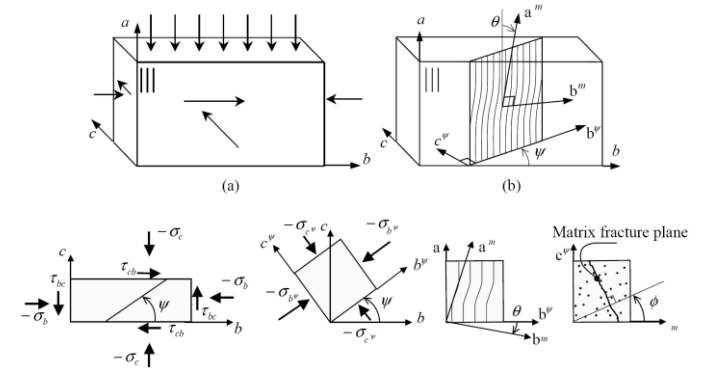

$$\sigma_n = \frac{\tilde{\sigma}_{b^m} + \tilde{\sigma}_{c^{\psi}}}{2} + \frac{\tilde{\sigma}_{b^m} - \tilde{\sigma}_{c^{\psi}}}{2} \cos(2\phi) + \tilde{\sigma}_{b^m c^{\psi}} \sin(2\phi)$$

$$\tau_T = -\frac{\tilde{\sigma}_{b^m} - \tilde{\sigma}_{c^{\psi}}}{2} \sin(2\phi) + \tilde{\sigma}_{b^m c^{\psi}} \cos(2\phi)$$

$$\tau_L = \tilde{\sigma}_{a^m b^m} \cos(\phi) + \tilde{\sigma}_{c^{\psi} a^m} \sin(\phi)$$

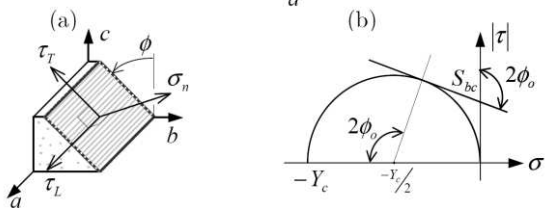

$\phi_0$ : fracture plane for pure compression  
 $\phi$ : fracture plane under general loading

\*MAT\_261 (\*MAT\_LAMINATED\_FRACTURE\_DAIMLER\_PINHO):

- linear damage laws

$$\hat{\sigma} = (1 - d_a)[\tilde{\sigma}_{11}, \tilde{\sigma}_{22}, \tilde{\sigma}_{12}, \tilde{\sigma}_{23}, \tilde{\sigma}_{31}]$$

$$\hat{\sigma} = (1 - d_{kink})[\tilde{\sigma}_{11}, \tilde{\sigma}_{22}, \tilde{\sigma}_{12}, \tilde{\sigma}_{23}, \tilde{\sigma}_{31}]$$

$$\hat{\sigma} = (1 - d_{mat})[\tilde{\sigma}_{22}, \tilde{\sigma}_{12}, \tilde{\sigma}_{23}, \tilde{\sigma}_{31}]$$

$$\hat{\sigma} = (1 - d_{mac})[\tilde{\sigma}_{22}, \tilde{\sigma}_{12}, \tilde{\sigma}_{23}, \tilde{\sigma}_{31}]$$

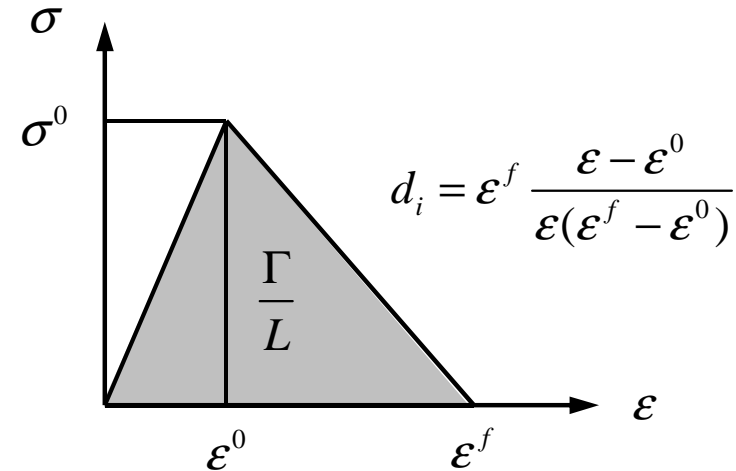

$\Gamma_a, \Gamma_{kink}, \Gamma_b, \Gamma_T, \Gamma_L$ :

fracture toughness from: CT, CC, 4-point bending, mode II interlaminar fracture (T,L)

$L$ :

internal (characteristic) length for objectivity (localization!)

**\*MAT\_261** (\*MAT\_LAMINATED\_FRACTURE\_DAIMLER\_PINHO):

- in-plane shear behavior

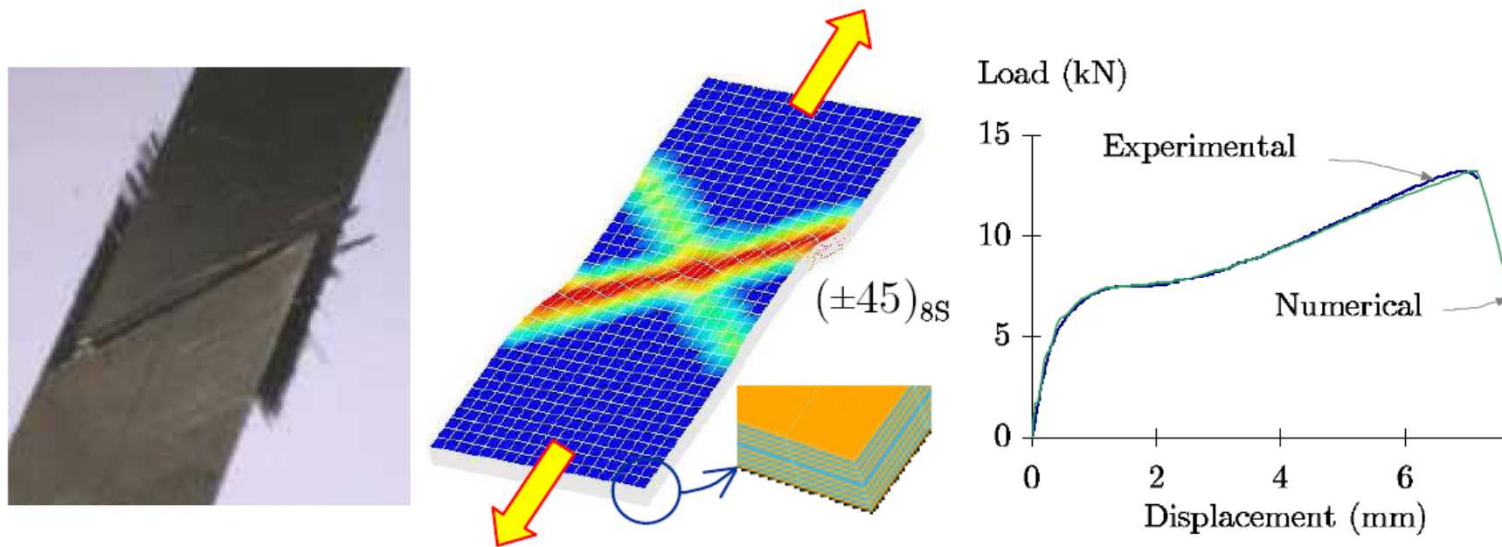

1D plasticity formulation with combined isotropic/kinematic hardening – coupled with linear damage model

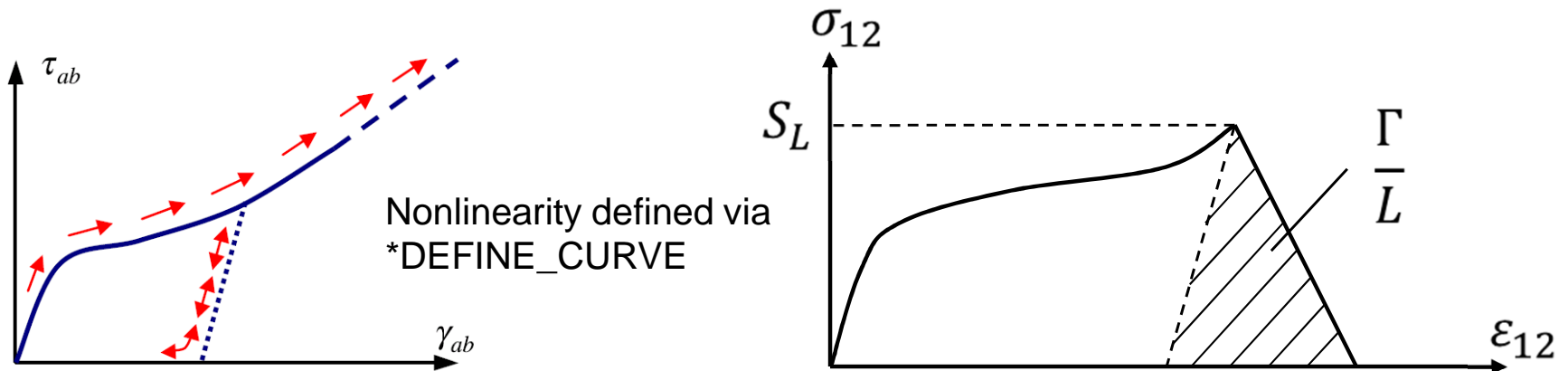

# Material models for intralaminar failure

**\*MAT\_261** (\*MAT\_LAMINATED\_FRACTURE\_DAIMLER\_PINHO):

	1	2	3	4	5	6	7	8	
elastic, orthotropic parameters	Card 1	MID	RO	EA	EB	EC	PRBA	PRCA	PRCB
	Card 2	GAB	GBC	GCA	AOPT	DAF	DKF	DMF	EFS
material coos	Card 3	XP	YP	ZP	A1	A2	A3		
	Card 4	V1	V2	V3	D1	D2	D3	MANGLE	
model parameter	Card 5	ENKINK	ENA	ENB	ENT	ENL			
	Card 6	XC	XT	YC	YT	SL			
	Card 7	FIO	SIGY	LCSS	BETA	PFL	PUCK	SOFT	

DAF: flag to control failure of an IP based on longitudinal (fiber) tensile failure

DKF: flag to control failure of an IP based on longitudinal (fiber) compressive failure

DMF: flag to control failure of an IP based on transverse (matrix) failure

EFS: Max. effect. Strain for element layer failure. A value of unity would equal 100% strain

ENKINK: Fracture toughness for longitudinal (fiber) compressive failure mode

ENA: Fracture toughness for longitudinal (fiber) tensile failure mode

ENB: Fracture toughness for intralaminar matrix tensile failure

ENT: Fracture toughness for intralaminar matrix transverse shear failure

ENL: Fracture toughness for intralaminar matrix longitudinal shear failure

XC: longitudinal compressive strength

XT: longitudinal tensile strength

YC: transverse compressive strength

YT: transverse tensile strength

SL: longitudinal shear strength

FIO: fracture angle in pure transverse compression (in degrees, default=53.0)

SIGY: In-plane shear yield stress

LCSS: Load curve ID which defines the non-linear in-plane shear-stress as a function of in-plane shear-strain

BETA: hardening parameter for in-plane shear plasticity

PFL: Percentage of layer which must fail before crashfront is initiated.

PUCK: flag to post-process Puck's inter-fiber-failure criterion

SOFT: reduction factor for strength in crashfront elements

\*MAT\_261 (\*MAT\_LAMINATED\_FRACTURE\_DAIMLER\_PINHO):

- 1-Element-Test, Single-Layer ('SHELL', ELFORM=2)

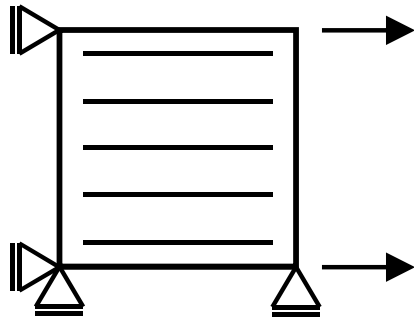

Material Parameter:  
 EA= 132.0 [kN/mm<sup>2</sup>]  
 XT= 1.95 [kN/mm<sup>2</sup>]  
 XC= 1.35 [kN/mm<sup>2</sup>]  
 ENA=0.05 [kN/mm]  
 ENKINK=0.02 [kN/mm]  
 EFS=0.05

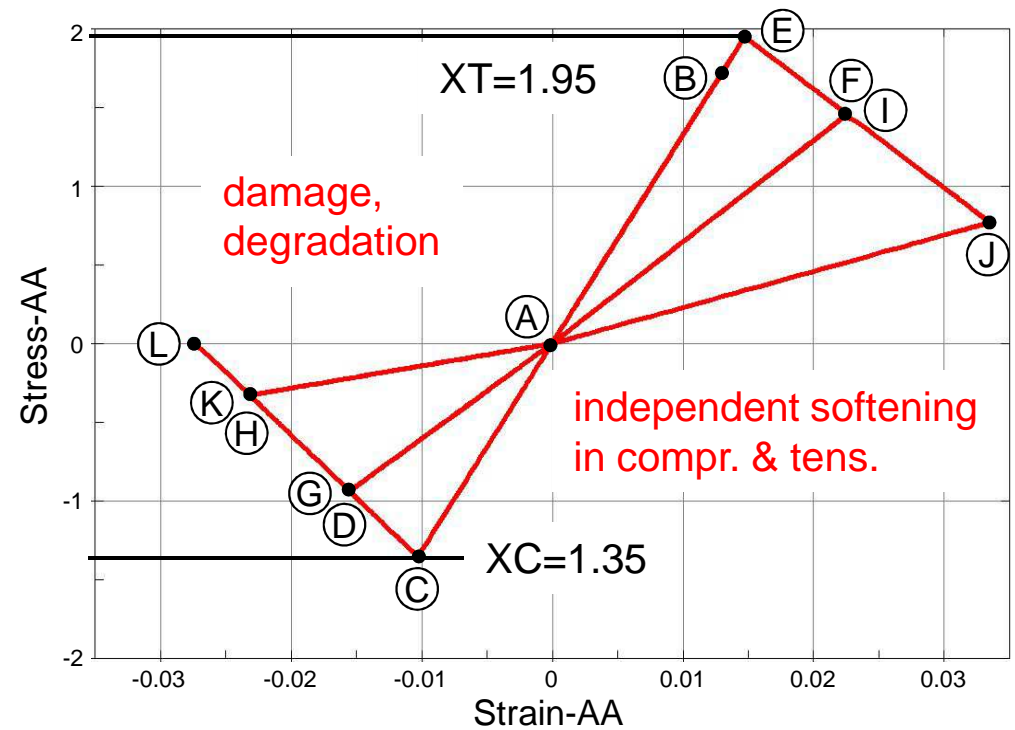
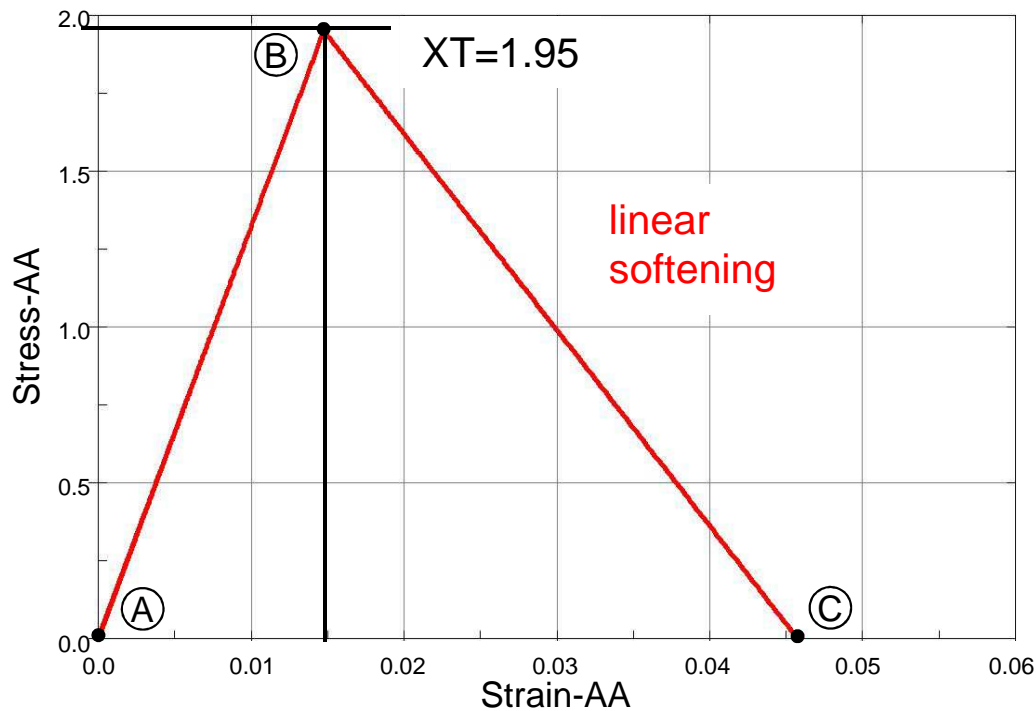
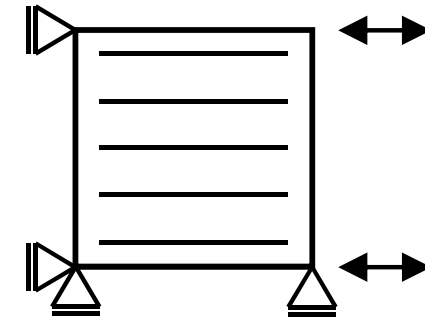

**\*MAT\_261** (\*MAT\_LAMINATED\_FRACTURE\_DAIMLER\_PINHO):

- 1-Element-Test, Single-Layer ('SHELL', ELFORM=2)
- Cyclic test with a +/-45° layup (A-M)

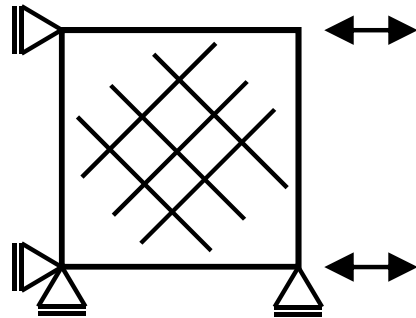

Material Parameter:  
 GAB= 4.6 [kN/mm<sup>2</sup>]  
 ENT= 0.006 [kN/mm]  
 ENL= 0.006 [kN/mm]  
 SL= 0.149 [kN/mm<sup>2</sup>]

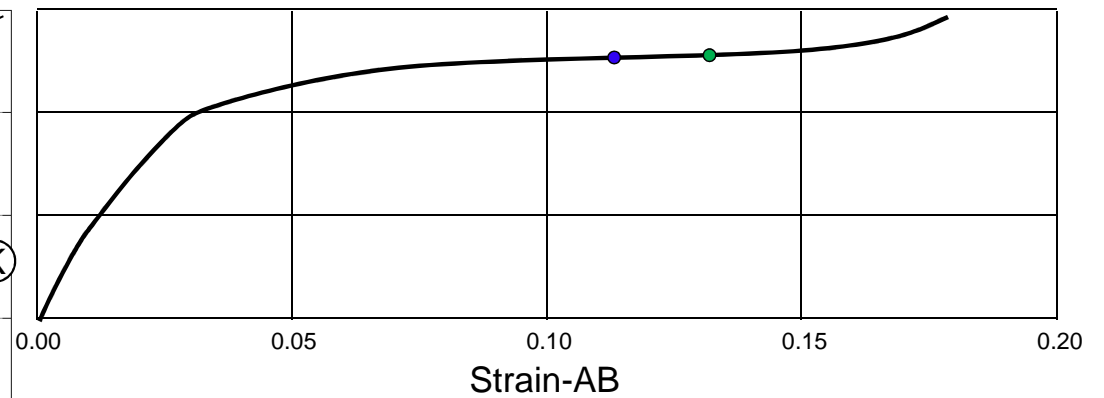
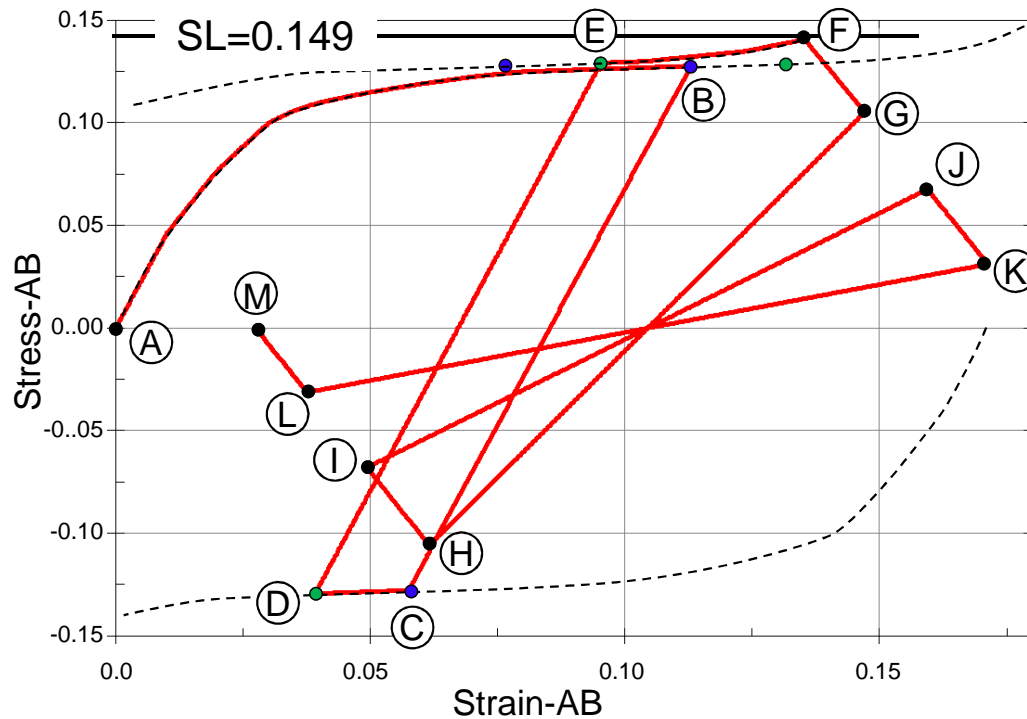

shear non-linearity with \*DEFINE\_CURVE



**\*MAT\_261** (\*MAT\_LAMINATED\_FRACTURE\_DAIMLER\_PINHO):

- Extra History Variables (→ set NEIPS in \*DATABASE\_EXTENT\_BINARY)

SHELLS / TSHELLS / SOLIDS		
1	fa	damage activation function: fiber tensile mode
2	fkink	damage activation function: fiber compressive mode
3	fmat	damage activation function: matrix mode
5	da	damage variable: fiber tension
6	dkink	damage variable: fiber compression
7	dmat	damage variable: transverse direction
9	dam	damage parameter (SOFT)
10	fmt_p	Puck's inter-fiber-failure criterion: tensile matrix mode
11	fmc_p	Puck's inter-fiber-failure criterion: compressive matrix mode
12	theta_p	Puck's inter-fiber-failure criterion: angle of fracture plane

fa, fkink, fmat:	0→1-elastic;	1-failure criterion reached
da; dkink; dmat:	0-elastic;	1-fully damaged
dam:	-1-intact;	0-failed; 10e-8-crashfront
fmt_p; fmc_p, theta_p:	0→1-elastic;	1-failure criterion reached

\*MAT\_262 (\*MAT\_LAMINATED\_FRACTURE\_DAIMLER\_CAMANHO):

■ constitutive relation

$$\boldsymbol{\varepsilon} = \mathbf{H} : \boldsymbol{\sigma} \rightarrow \boldsymbol{\sigma} = \mathbf{H}^{-1} : \boldsymbol{\varepsilon}$$

$$\mathbf{H} = \begin{bmatrix} \frac{1}{(1-d_1)E_1} & -\frac{\nu_{21}}{E_2} & 0 \\ -\frac{\nu_{12}}{E_1} & \frac{1}{(1-d_2)E_2} & 0 \\ 0 & 0 & \frac{1}{(1-d_6)G_{12}} \end{bmatrix}$$

5 damage variables

$$d_{1-}(r_{1-}, r_{1+}); d_{1+}(r_{1+}); d_{2-}(r_{2-}); d_{2+}(r_{2+}); d_6(r_{2+})$$

$$d_1 = d_{1+} \frac{\langle \sigma_{11} \rangle}{|\sigma_{11}|} + d_{1-} \frac{\langle -\sigma_{11} \rangle}{|\sigma_{11}|}$$

$$d_2 = d_{2+} \frac{\langle \sigma_{22} \rangle}{|\sigma_{22}|} + d_{2-} \frac{\langle -\sigma_{22} \rangle}{|\sigma_{22}|}$$

■ 4 failure criteria (LaRC03/04)

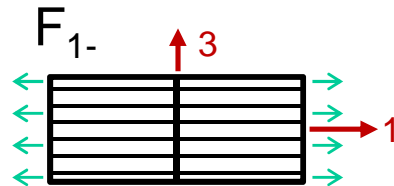

a) Longitudinal tensile fracture

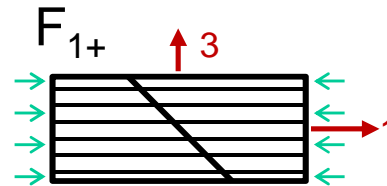

b) Longitudinal compressive fracture

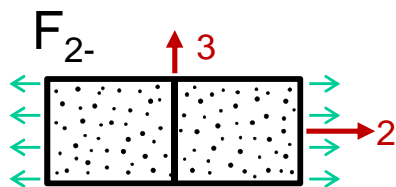

c) Transverse fracture with  $\alpha=0^\circ$

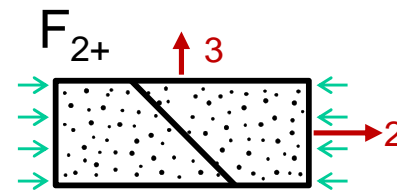

d) Transverse fracture with  $\alpha=53^\circ$

damage activation functions

$$F_{1-} = \phi_{1-} - r_{1-} \leq 0$$

$$F_{2-} = \phi_{2-} - r_{2-} \leq 0$$

$$F_{1+} = \phi_{1+} - r_{1+} \leq 0$$

$$F_{2+} = \phi_{2+} - r_{2+} \leq 0$$

\*MAT\_262 (\*MAT\_LAMINATED\_FRACTURE\_DAIMLER\_CAMANHO):

- failure surface (assembly of 4 sub-surfaces)

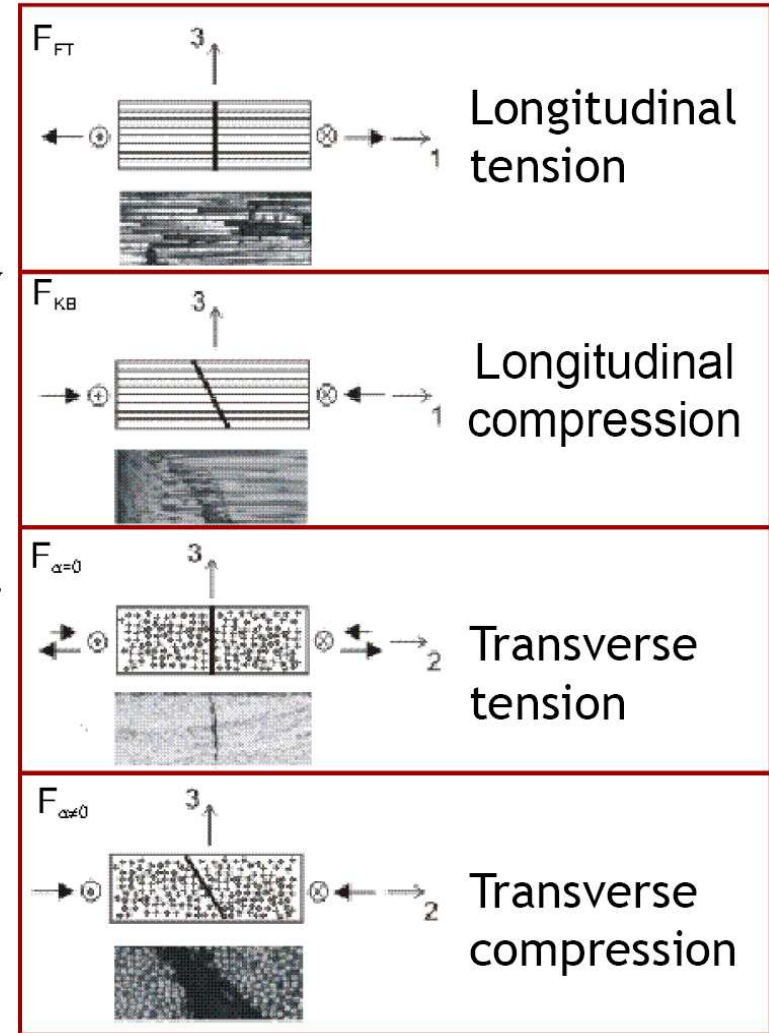
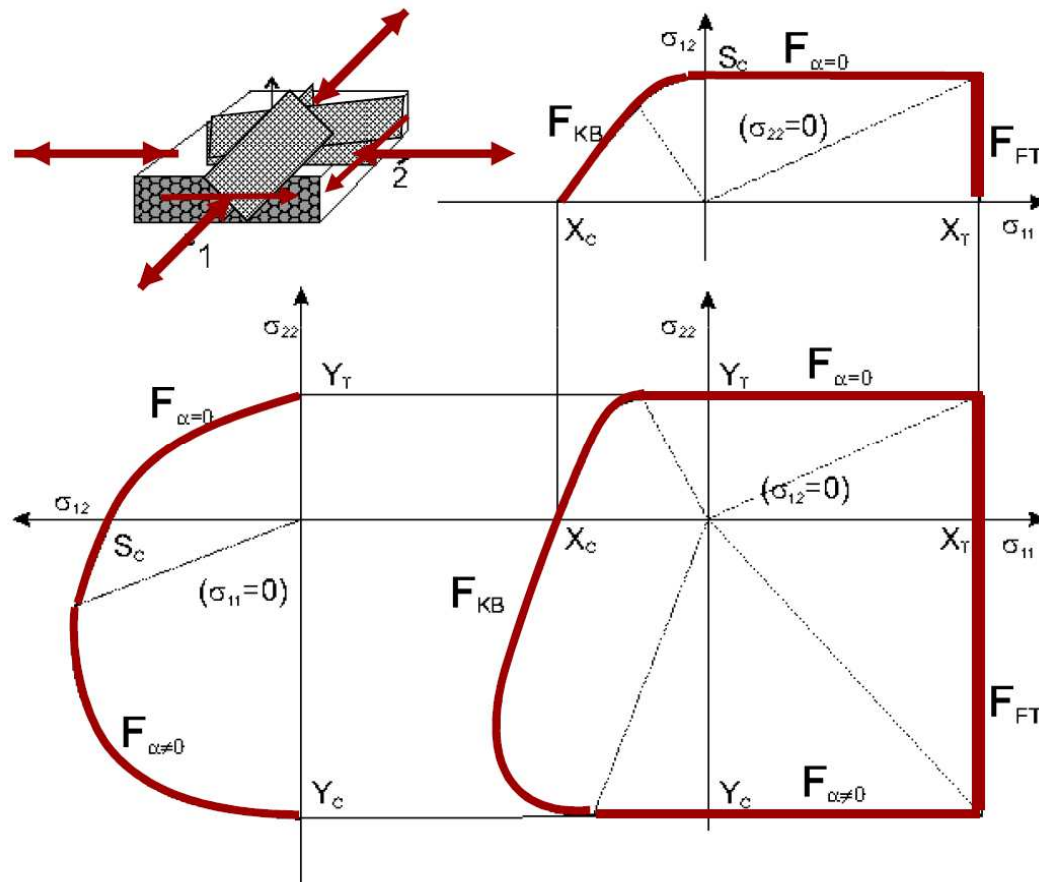

\*MAT\_262 (\*MAT\_LAMINATED\_FRACTURE\_DAIMLER\_CAMANHO):

- physically based failure criteria
- continuum damage model

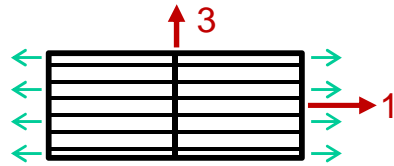

a) Tensile fibre mode  
(maximum strain – LaRC04)

$$\phi_{1+} = \frac{\tilde{\sigma}_{11} - \nu_{12} \tilde{\sigma}_{22}}{X_T}$$

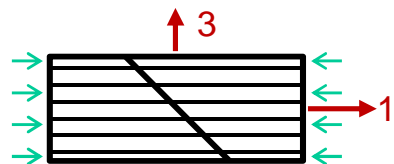

b) Compressive fibre mode (LaRC03)  
(transf. fracture plane)

$$\phi_{1-} = \frac{\langle |\tilde{\sigma}_{12}^m| + \mu_L \tilde{\sigma}_{22}^m \rangle}{S_L}$$

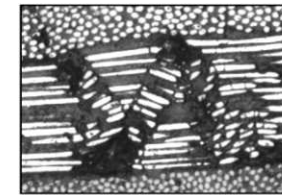

Fiber Compression

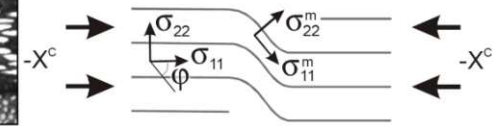

$$\tilde{\sigma}_{22}^m = \tilde{\sigma}_{11} \sin^2(\varphi^c) + \tilde{\sigma}_{22} \cos^2(\varphi^c) - 2|\tilde{\sigma}_{12}| \sin(\varphi^c) \cos(\varphi^c)$$

$$\tilde{\sigma}_{12}^m = (\tilde{\sigma}_{22} - \tilde{\sigma}_{11}) \sin(\varphi^c) \cos(\varphi^c) + |\tilde{\sigma}_{12}| (\cos^2(\varphi^c) - \sin^2(\varphi^c))$$

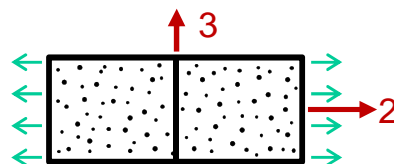

c) Tensile matrix mode  
(LaRc04)

$$\phi_{2+} = \sqrt{(1-g) \frac{\tilde{\sigma}_{22}}{Y_T} + g \left( \frac{\tilde{\sigma}_{22}}{Y_T} \right)^2 + \left( \frac{\tilde{\sigma}_{12}}{S_L} \right)^2} \quad (\tilde{\sigma}_{22} \geq 0)$$

$$\phi_{2+} = \frac{\langle |\tilde{\sigma}_{12}| + \mu_L \tilde{\sigma}_{22} \rangle}{S_L} \quad (\tilde{\sigma}_{22} < 0)$$

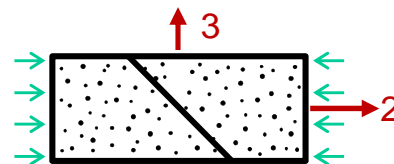

d) Compressive matrix mode (LaRC04)  
(transf. fracture plane)

$$\phi_{2-} = \sqrt{\left( \frac{\tau_T^{eff}}{S_T} \right)^2 + \left( \frac{\tau_L^{eff}}{S_L} \right)^2}$$

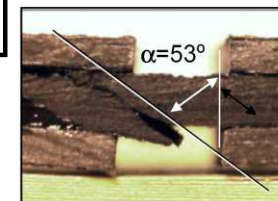

Matrix Compression and Shear

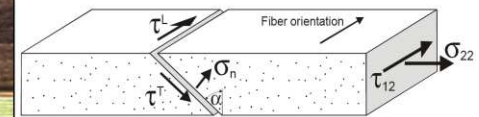

$$\tau_T^{eff} = \langle -\tilde{\sigma}_{22} \cos(\alpha_0) [\sin(\alpha_0) - \mu_T \cos(\alpha_0) \cos(\theta)] \rangle$$

$$\tau_L^{eff} = \langle \cos(\alpha_0) [|\tilde{\sigma}_{12}| + \mu_L \tilde{\sigma}_{22} \cos(\alpha_0) \sin(\theta)] \rangle$$

\*MAT\_262 (\*MAT\_LAMINATED\_FRACTURE\_DAIMLER\_CAMANHO):

- evolution of threshold (internal) variables ( $r \in [1 \rightarrow \infty]$ )

compression:	$r_{1-/2-}^{n+1} = \max\{1, r_{1-/2-}^n, \phi_{1-/2-}^{n+1}\}$	← no damage due to crack (tension); crack closure
tension:	$r_{1+/2+}^{n+1} = \max\{1, r_{1+/2+}^n, r_{1-/2-}^{n+1}, \phi_{1+/2+}^{n+1}\}$	

- evolution of damage variables ( $d \in [0 \rightarrow 1]$ )

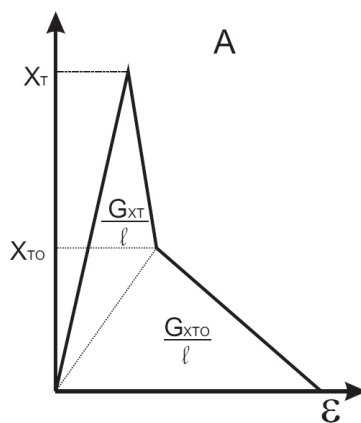

bi-linear in fiber direction

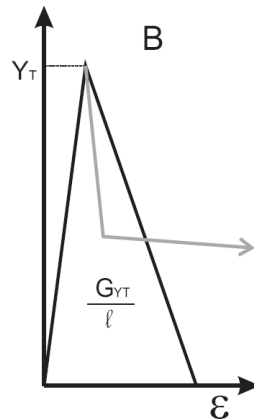

linear in transverse direction

$d(r) = 1 - \frac{m(X, G)}{E} - \frac{n(X, m)}{E\varepsilon(r)}$
--

$G_{XT}, G_{XC}, G_{YT}, G_{YC}, G_{SL}$

fracture toughness from: CT, CC, DCB, -, 4-ENF

$\ell$ : internal (characteristic) length for objectivity (localization!)

**\*MAT\_262** (\*MAT\_LAMINATED\_FRACTURE\_DAIMLER\_CAMANHO):

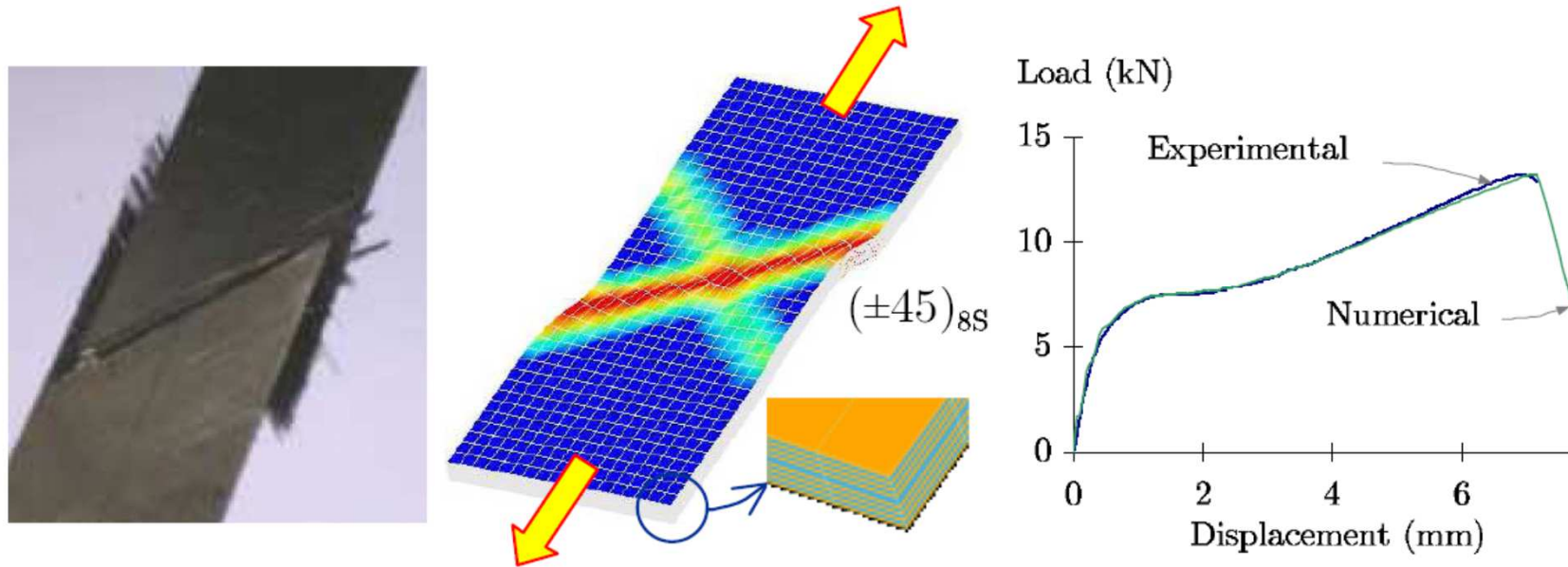

1D elasto-plastic formulation with combined iso/kin hardening – coupled to a linear damage evolution law

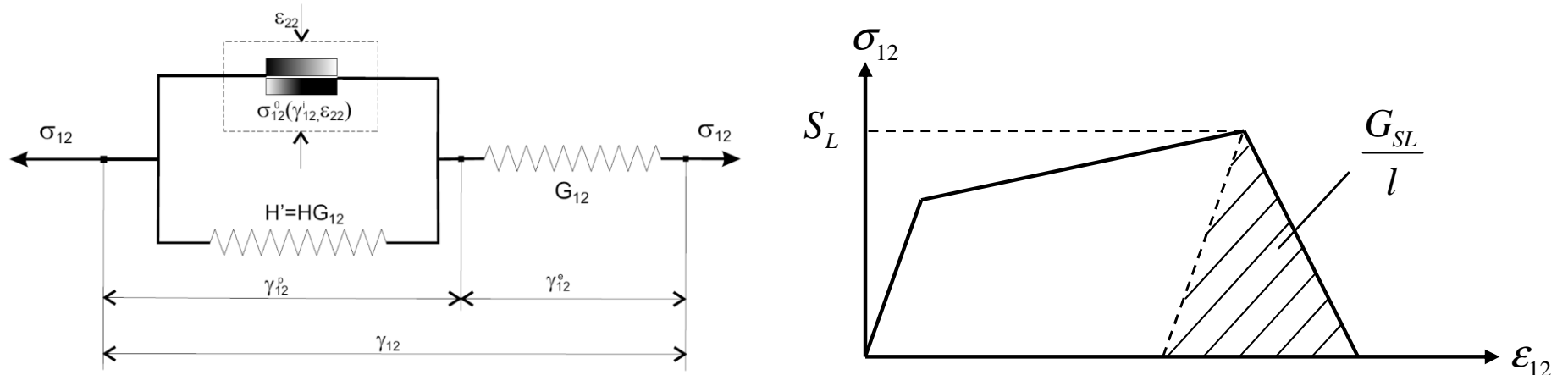

# Material models for intralaminar failure

**\*MAT\_262** (\*MAT\_LAMINATED\_FRACTURE\_DAIMLER\_CAMANHO):

	1	2	3	4	5	6	7	8	
elastic, orthotropic parameters	Card 1	MID	RO	EA	EB	EC	PRBA	PRCA	PRCB
	Card 2	GAB	GBC	GCA	AOPT	DAF	DKF	DMF	EFS
material coos	Card 3	XP	YP	ZP	A1	A2	A3		
	Card 4	V1	V2	V3	D1	D2	D3	MANGLE	
model parameter	Card 5	GXC	GXT	GYC	GYT	GSL	GXCO	GXTO	
	Card 6	XC	XT	YC	YT	SL	XCO	XTO	
	Card 7	FIO	SIGY	ETAN	BETA	PFL	PUCK	SOFT	

DAF: flag to control failure of an IP based on longitudinal (fiber) tensile failure

DKF: flag to control failure of an IP based on longitudinal (fiber) compressive failure

DMF: flag to control failure of an IP based on transverse (matrix) failure

EFS: Max. effect. Strain for element layer failure. A value of unity would equal 100% strain

GXC: Fracture toughness for longitudinal (fiber) compressive failure mode

GXT: Fracture toughness for longitudinal (fiber) tensile failure mode

GYC: Fracture toughness for transv. compr. fail.

GYT: Fracture toughness for transv. tens. fail.

GSL: Fracture toughness for in-plane shear fail.

GXCO: Frac. tough. long. compr. fail. bi-lin. damage

GXTO: Frac. tough. long. tens. fail. bi-lin. damage

XC: longitudinal compressive strength

XT: longitudinal tensile strength

YC: transverse compressive strength

YT: transverse tensile strength

SL: shear strength ab-plane

XCO: long. compr. strength at inflection point

XTO: long. tens. strength at inflection point

FIO: fracture angle in pure transverse compression (in degrees, default=53.0)

SIGY: In-plane shear yield stress

ETAN: tangent modulus for in-plane shear plasticity

BETA: hardening parameter for in-plane shear plasticity

PFL: Percentage of layer which must fail before crashfront is initiated.

PUCK: flag to post-process Puck's inter-fiber-failure criterion

SOFT: reduction factor for strength in crashfront elements

\*MAT\_262 (\*MAT\_LAMINATED\_FRACTURE\_DAIMLER\_CAMANHO):

- 1-Element-Test, Single-Layer ('SHELL', ELFORM=2)

fiber tensile load (A-D)

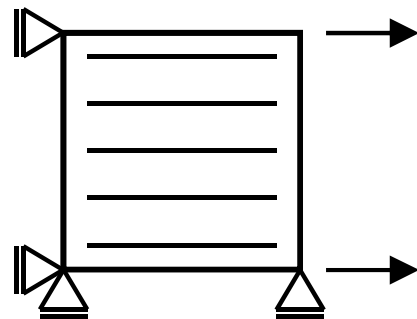

Material Parameter:  
 $EA = 132.0$  [kN/mm<sup>2</sup>]  
 $XT = 1.95$  [kN/mm<sup>2</sup>]  
 $XC = 1.35$  [kN/mm<sup>2</sup>]  
 $GXT/GXC = 0.015$  [kN/mm]  
 $GXTO/GXCO = 0.01$  [kN/mm]  
 $XTO/XCO = 0.4$  [kN/mm<sup>2</sup>]

fiber cyclic load (A-K)

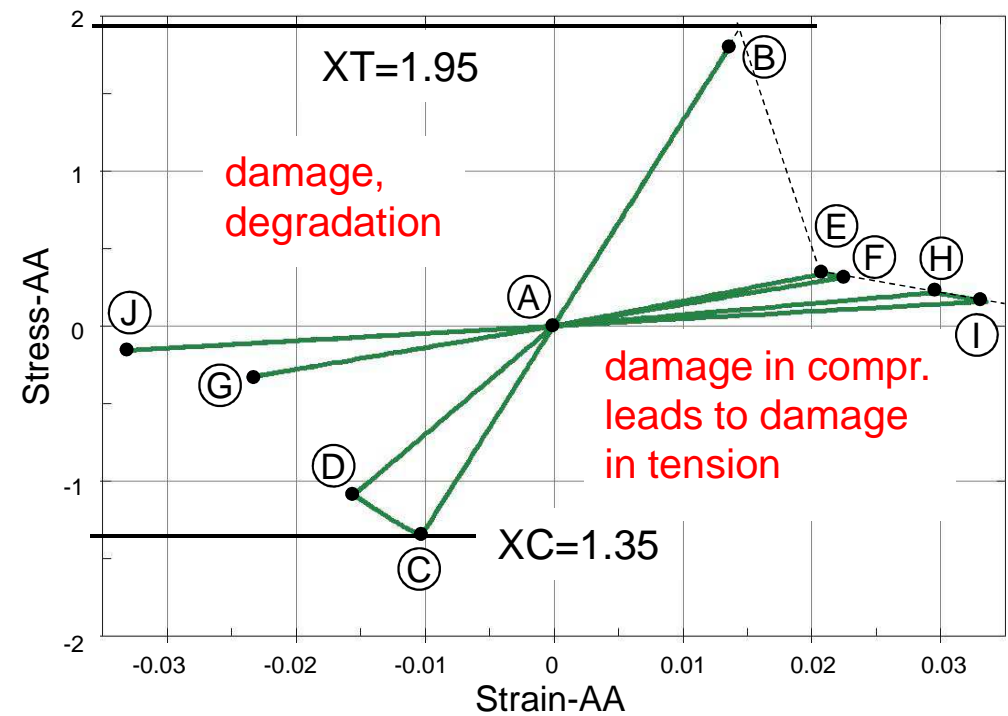
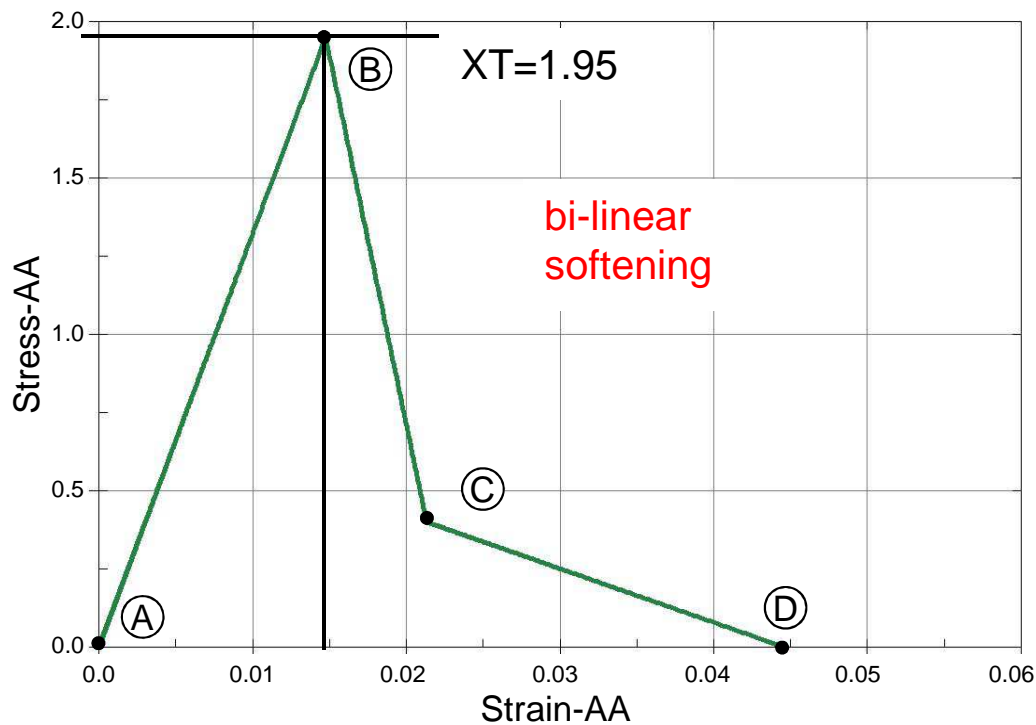
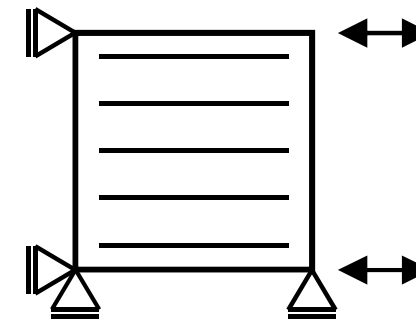



**\*MAT\_262** (\*MAT\_LAMINATED\_FRACTURE\_DAIMLER\_CAMANHO):

- 1-Element-Test, Single-Layer ('SHELL', ELFORM=2)
- Cyclic test with a +/-45° layup (A-M)

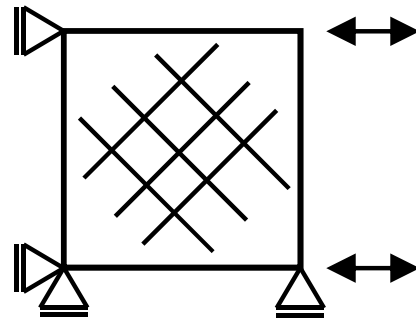

Material Parameter:  
 GAB= 4.6 [kN/mm<sup>2</sup>]  
 GSL= 0.006 [kN/mm]  
 SIGY= 0.115 [kN/mm<sup>2</sup>]  
 ETAN= 0.18 [kN/mm<sup>2</sup>]  
 SL= 0.149 [kN/mm<sup>2</sup>]

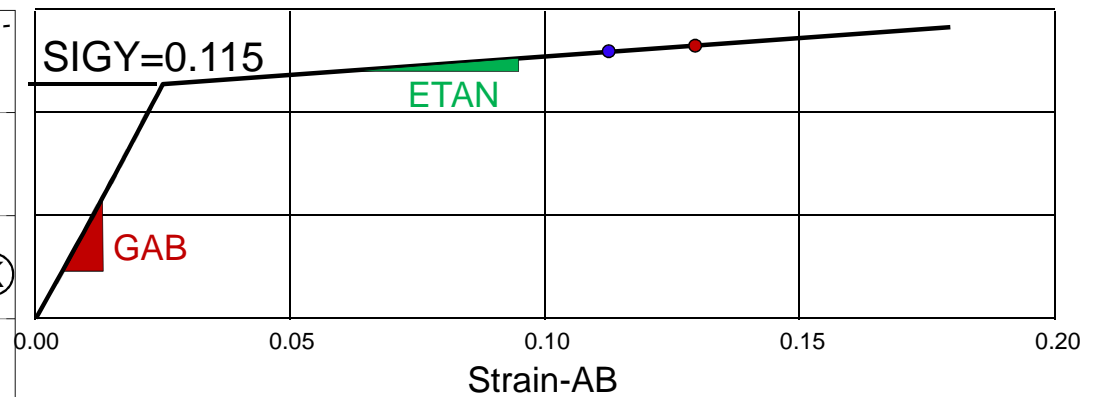
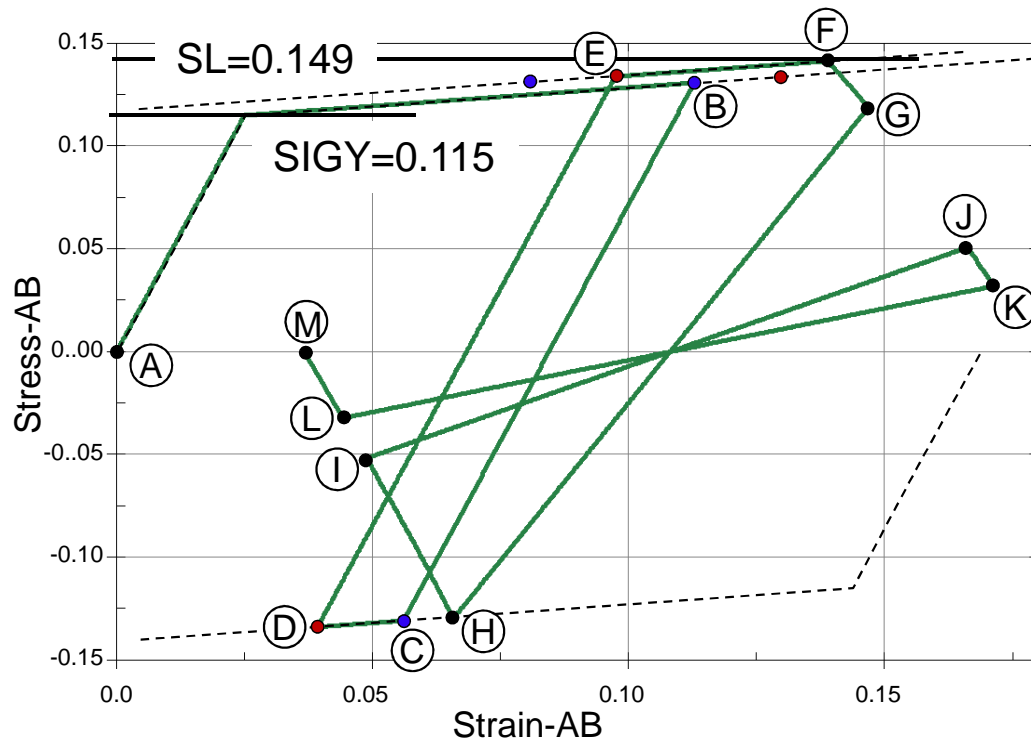

**\*MAT\_262** (\*MAT\_LAMINATED\_FRACTURE\_DAIMLER\_CAMANHO):

- Extra History Variables (→ set NEIPS in \*DATABASE\_EXTENT\_BINARY)

SHELLS / TSHELLS / SOLIDS		
1	$\Phi_{1+}$	damage activation function: fiber tensile mode
2	$\Phi_{1-}$	damage activation function: fiber compressive mode
3	$\Phi_{2+}$	damage activation function: tensile matrix mode
4	$\Phi_{2-}$	damage activation function: compressive matrix mode
5	$d_{1+}$	damage variable: fiber tension
6	$d_{1-}$	damage variable: fiber compression
7	$d_2$	damage variable: transverse direction
8	$d_6$	damage variable: in-plane shear
9	dam	damage parameter (SOFT)
10	fmt_p	Puck's inter-fiber-failure criterion: tensile matrix mode
11	fmc_p	Puck's inter-fiber-failure criterion: compressive matrix mode
12	theta_p	Puck's inter-fiber-failure criterion: angle of fracture plane

$\Phi_i$ :	0→1-elastic;	1-failure criterion reached
$d_i$ :	0-elastic;	1-fully damaged
dam:	-1-intact;	0-failed; 10e-8-crashfront
fmt_p; fmc_p, theta_p:	0→1-elastic;	1-failure criterion reached

## comparison between different material models

- 1-Element-Test, Single-Layer ('SHELL', ELFORM=2)

fiber tensile load (A-E)

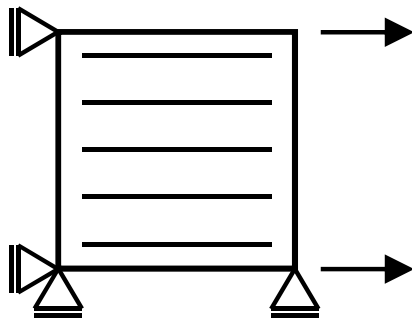

Material Parameter:  
 EA= 132.0 [kN/mm<sup>2</sup>]  
 XT= 1.95 [kN/mm<sup>2</sup>]  
 XC= 1.35 [kN/mm<sup>2</sup>]  
 ... (model dependent)

fiber cyclic load (A-K)

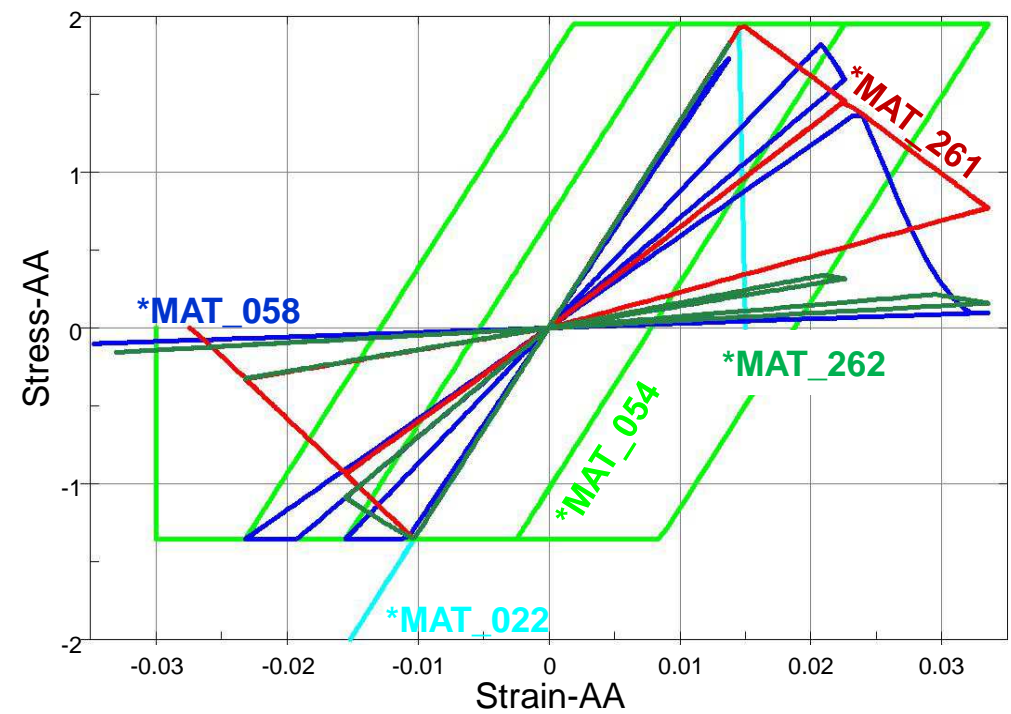
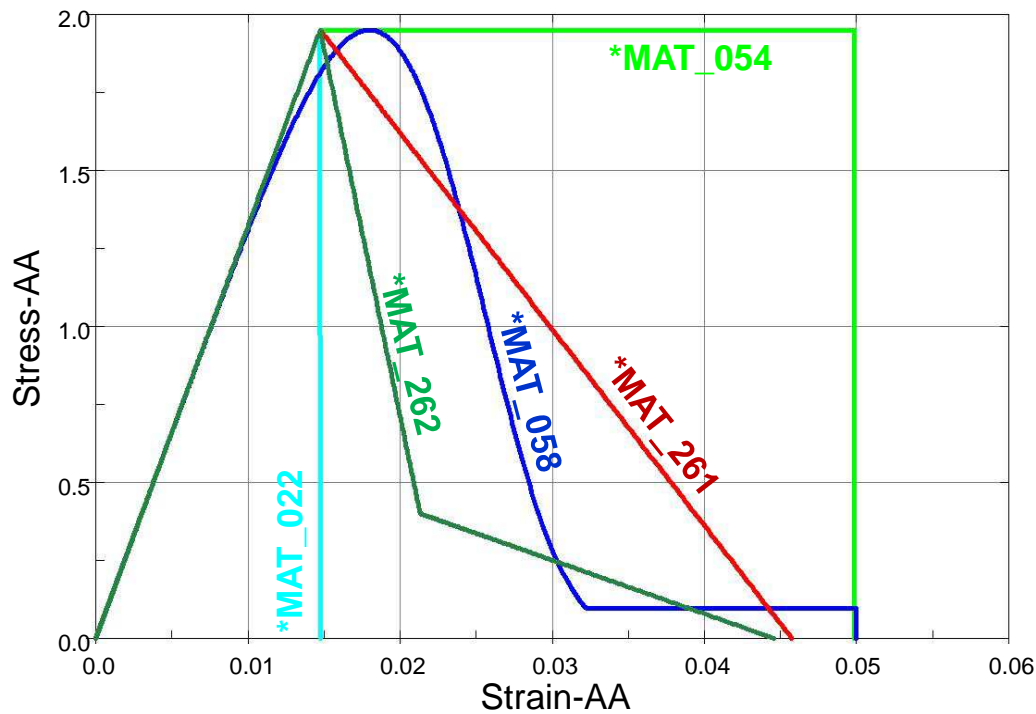
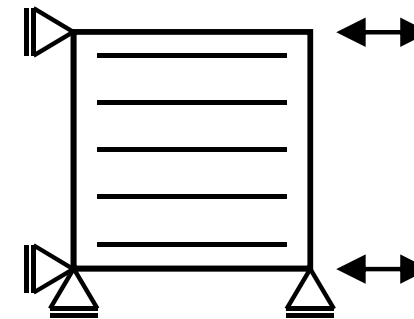

## comparison of the new material models (in-plane shear)

- 1-Element-Test, Single-Layer ('SHELL', ELFORM=2)
- Cyclic test with a +/-45° layup (A-M)

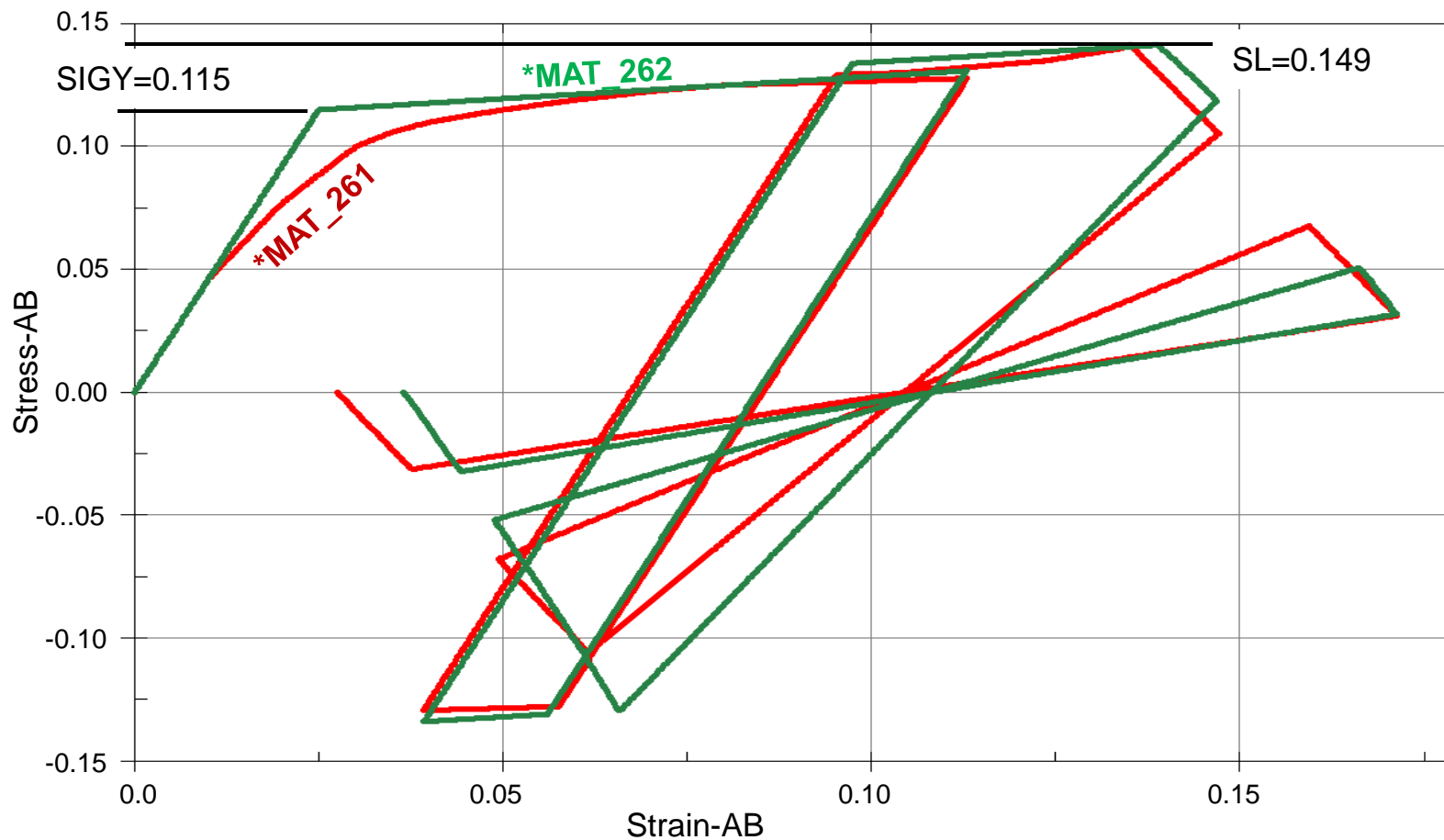
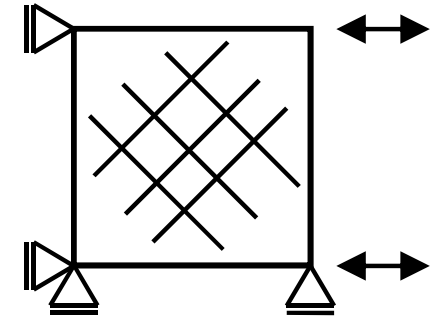



## \*MAT\_261 (Pinho)

## \*MAT\_262 (Camanho)

failure criterion may use 3D-stress state

failure criterion based on plane stress assumption

### fiber tension

maximum stress criterion

maximum strain criterion

### fiber compression

complex 3D-fiber kinking model, expensive search for controlling fracture plane

use constant fiber misalignment angle based on shear and longitudinal compressive strength

### matrix failure: transverse tension

search for controlling fracture plane

assume perpendicular fracture plane

### matrix failure: transverse compression/shear

search for controlling fracture plane

assume constant fracture plane angle (i.e. 53°)

### in-plane shear treatment

1D-plasticity model with combined (iso/kin) hardening based on \*DEFINE\_CURVE

1D-plasticity model with combined (iso/kin) linear hardening

### damage evolution

linear damage based on fracture toughness

bi-/linear damage based on fracture toughness

## summary

### \*MAT\_261: (\*MAT\_LAMINATED\_FRACTURE\_DAIMLER\_PINHO) (together with Daimler AG)

- ✓ solid, shell, tshell (3,5)
- ✓ linear elastic orthotropic
- ✓ coupled failure criteria (plane stress) – fracture plane:  
fiber tens./compr., matrix tens./compr.
- ✓ complex 3D fiber kinking model
- ✓ 1D plasticity formulation for in-plane shear
- ✓ linear damage evolution based on fracture toughness

available  
since R7.0

S.T. Pinho, L. Iannucci, P. Robinson:

Physically-based failure models and criteria for laminated fibre-reinforced composites with emphasis on fibre kinking:  
Part I: Development & Part II: FE implementation, Composites: Part A 37 (2006) 63-73 & 766-777

### \*MAT\_262: (\*MAT\_LAMINATED\_FRACTURE\_DAIMLER\_CAMANHO) (together with Daimler AG)

- ✓ solid, shell, tshell (3,5)
- ✓ linear elastic orthotropic
- ✓ coupled failure criteria (plane stress) – fracture plane
- ✓ 1D plasticity formulation for in-plane shear
- ✓ bi-linear damage evolution based on fracture toughness

available  
since R7.0

P. Maimí, P.P. Camanho, J.A. Mayugo, C.G. Dávila:

A continuum damage model for composite laminates:

Part I: Constitutive model & Part II: Computational implementation and validation, Mechanics of materials 39 (2007) 897-908 & 909-919

## Problem der Objektivität (Pinho und Camanho gleichermassen) – 1D-Beispiel

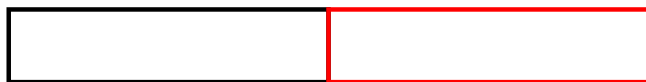
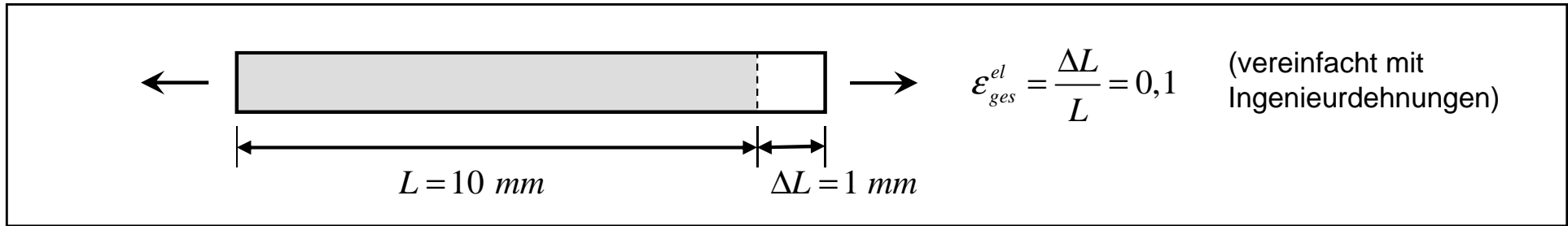

2 Elemente

FE-Diskretisierung



10 Elemente



$$\epsilon_{ges}^{el} = \frac{\Delta L}{L} = 0,1 \Rightarrow \epsilon_{ele}^{el} = \frac{\Delta L / 2}{L / 2} = 0,1$$

Elastische Verformung



$$\epsilon_{ges}^{el} = \frac{\Delta L}{L} = 0,1 \Rightarrow \epsilon_{ele}^{el} = \frac{\Delta L / 10}{L / 10} = 0,1$$



$$\epsilon_{ges}^{el} = \frac{\Delta L}{L} = 0,1 \Rightarrow \epsilon_{ele}^{el} = \frac{\Delta L}{L / 2} = 0,2$$

Lokalisierung (Verformung in einem Element)



$$\epsilon_{ges}^{el} = \frac{\Delta L}{L} = 0,1 \Rightarrow \epsilon_{ele}^{el} = \frac{\Delta L}{L / 10} = 1,0$$

Spannungen aus lokaler  $\sigma - \epsilon$ -Beziehung

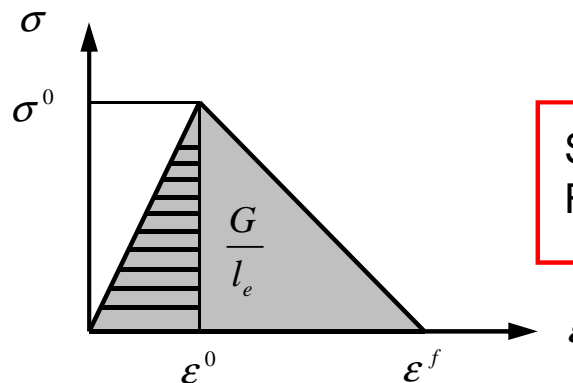

Skalierung mit charakteristischer FE-Elementlänge

## Problem der Objektivität (Pinho und Camanho gleichermassen)

- Gesamte Bruchenergie:

$$\frac{G}{l_e} = \frac{1}{2} \varepsilon^f \sigma^0 \rightarrow \varepsilon^f = \frac{2G}{l_e \sigma^0} \rightarrow l_e = \frac{2G}{\sigma^0 \varepsilon^f}$$

- Kriterium:  $\varepsilon^f \geq \varepsilon^0$

Daraus ergibt sich eine kritische, maximale Elementgröße

$$l_e^{cr} = \frac{2G}{\sigma^0 \varepsilon^0}$$

Diese ist Abhängig von den Materialparametern und liegt meist < 1mm!

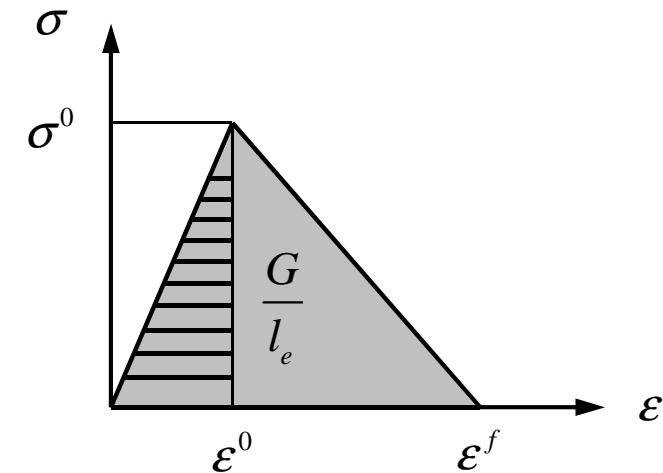

Lokalisierung:

Skalierung der Bruchenergie

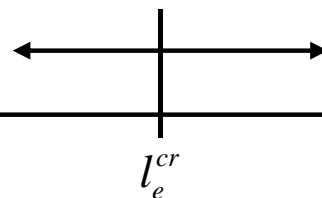

Anpassung der Materialparameter  
für benutzte Elementgröße



## three point bending of flat specimen

- single shell with a thickness of 4mm / carbon fibers in epoxy resin
  - $[0]_{5s}$  (fibers in longitudinal direction of the plate)
  - $[90]_{5s}$  (fibers in transverse direction of the plate)

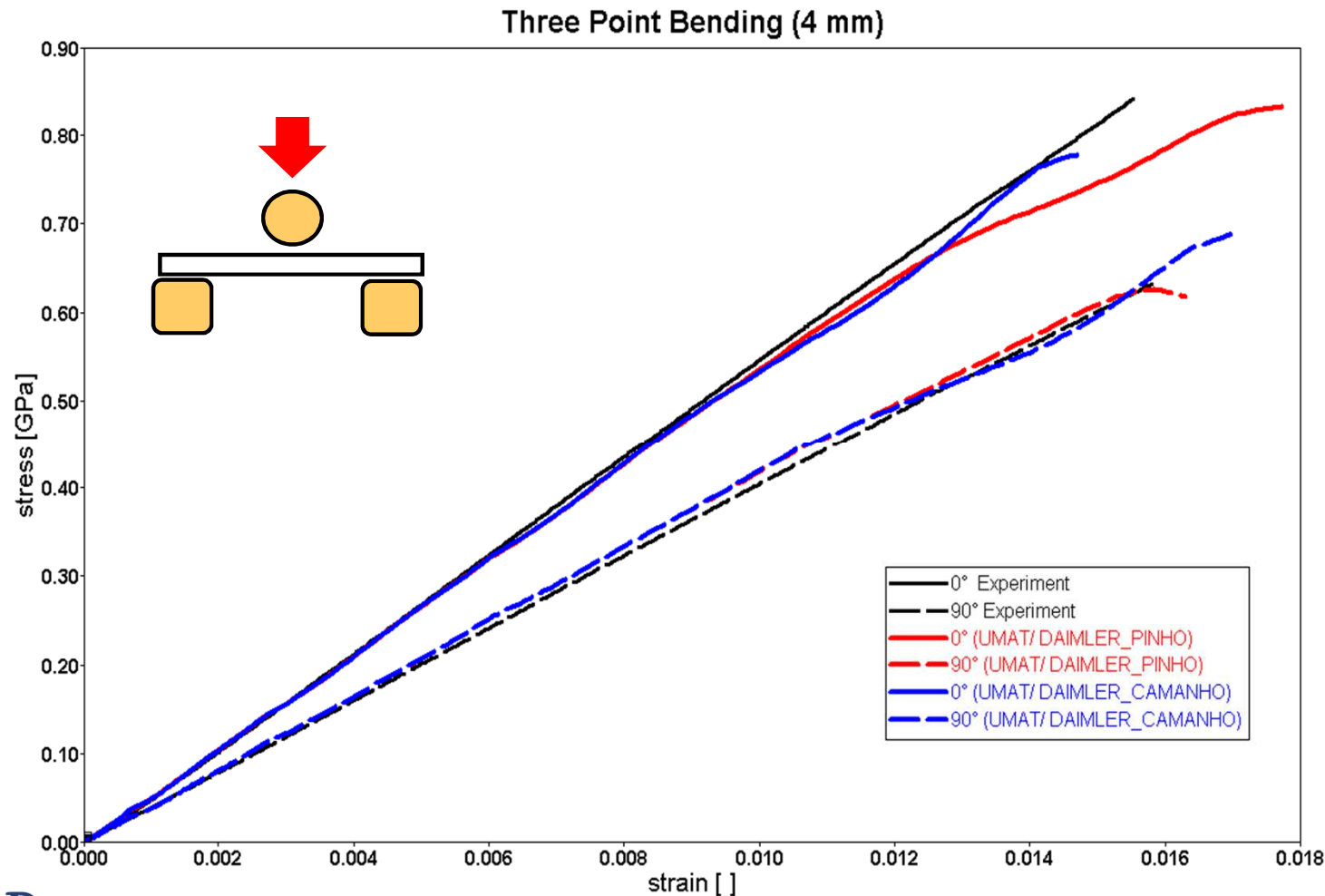

## three point bending of a hat profile

- single shell with a thickness of 2mm / carbon fibers in epoxy resin  
- [90 /0 /45 /-45 /0 /90 /-45 /45 /0 /90 ]

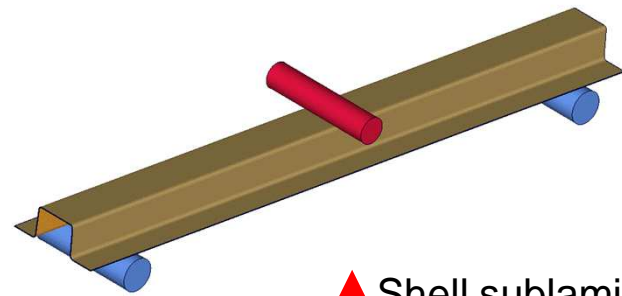

↑ Shell sublaminates  
Local failure

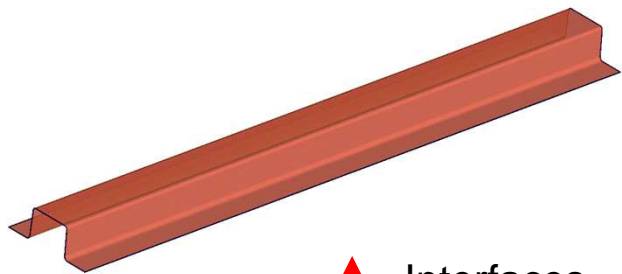

↑ Interfaces  
Local failure

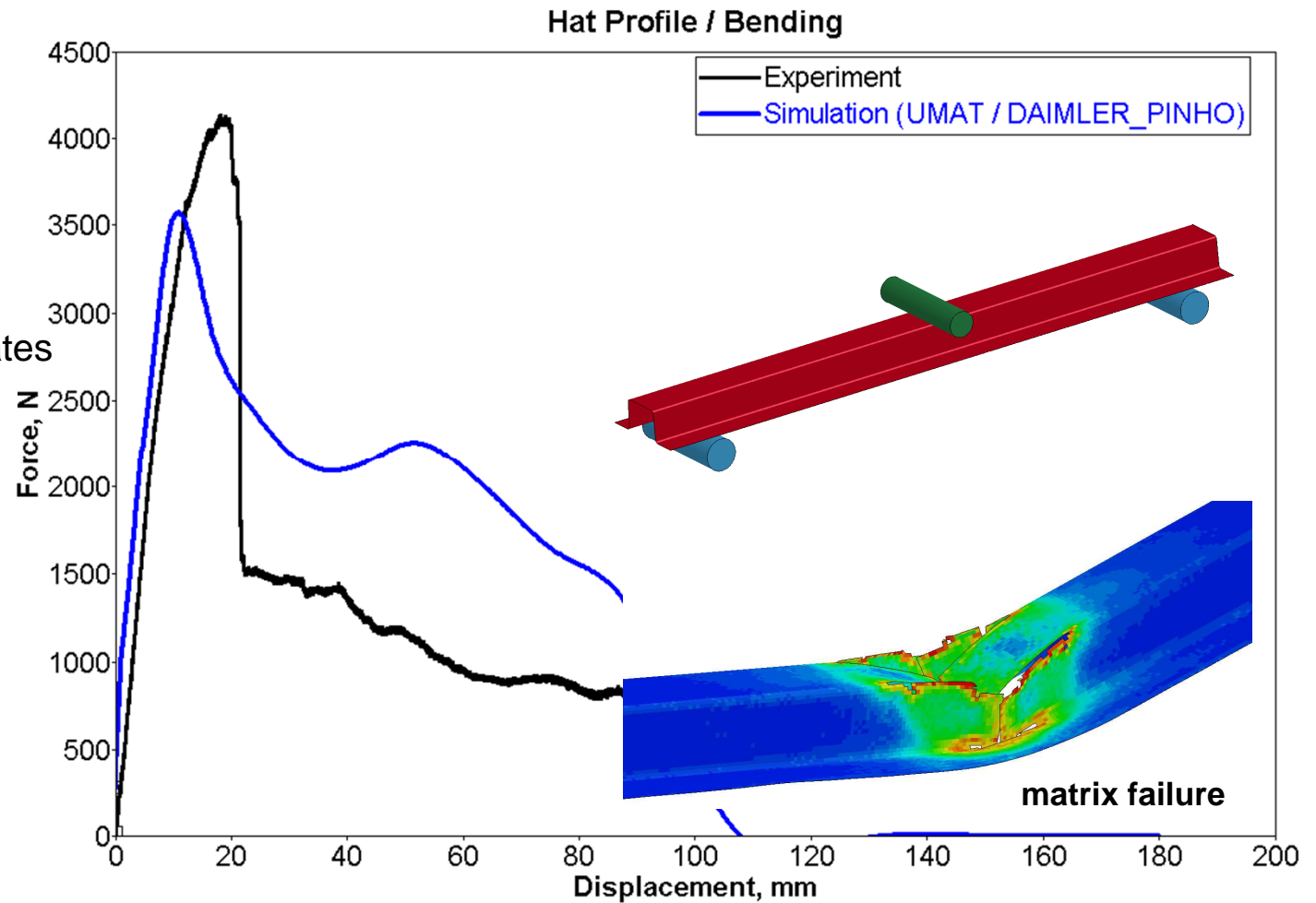

DAIMLER



## shear specimen

- single shell with a thickness of 2mm / carbon fibers in epoxy resin  
-  $[45^{\circ}/-45^{\circ}]_{3S}$

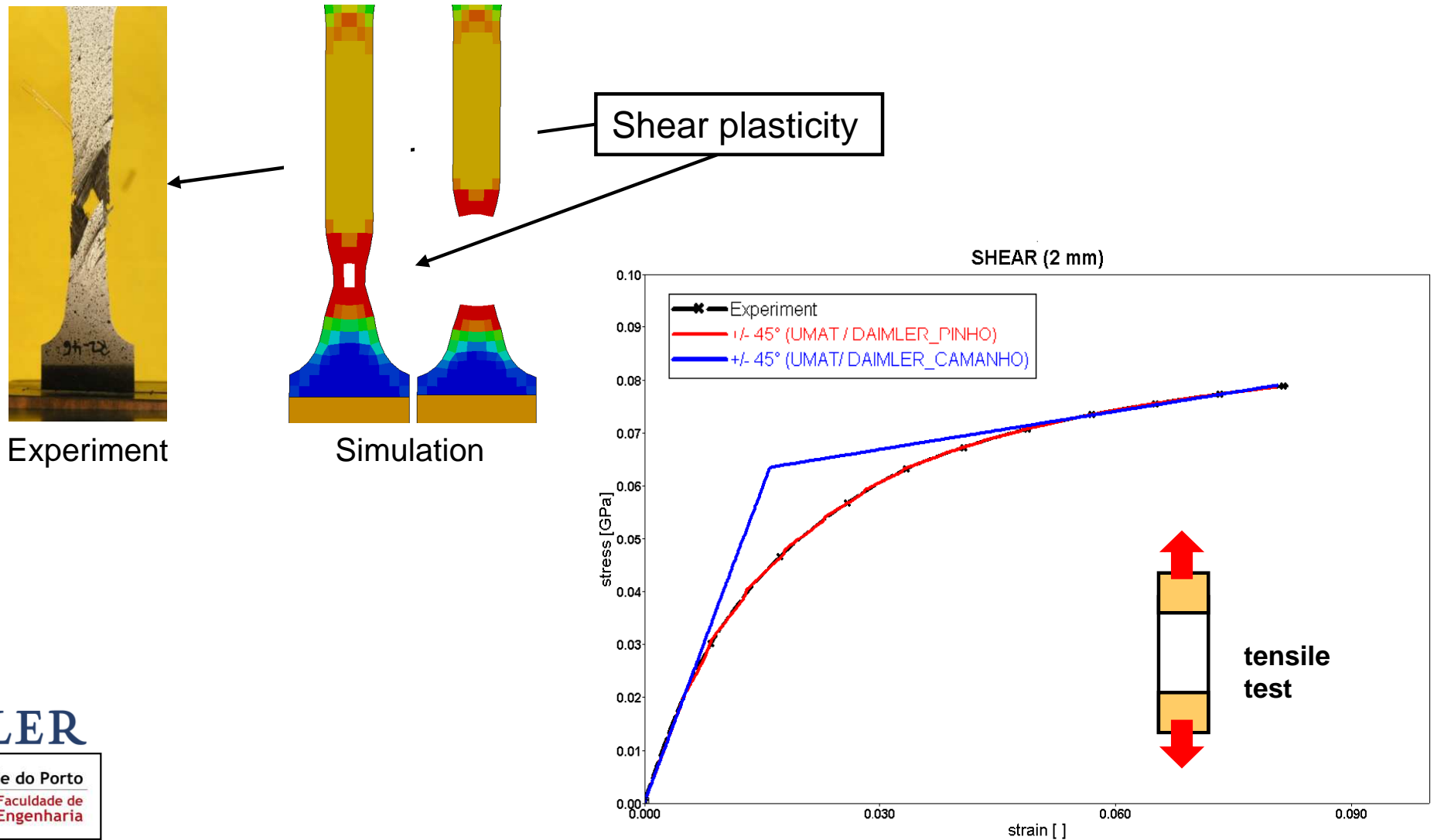

DAIMLER

Universidade do Porto  
FEUP Faculdade de Engenharia

## 3-Punkt-Biegung

- Auflager und Impaktor als starre Körper
- Spanngurte durch vorgespannte Balken
- Schweller mit geschichteten Schalenelementen (12 Schichten, *ELFORM=2*) und Materialmodell nach P. Camanho

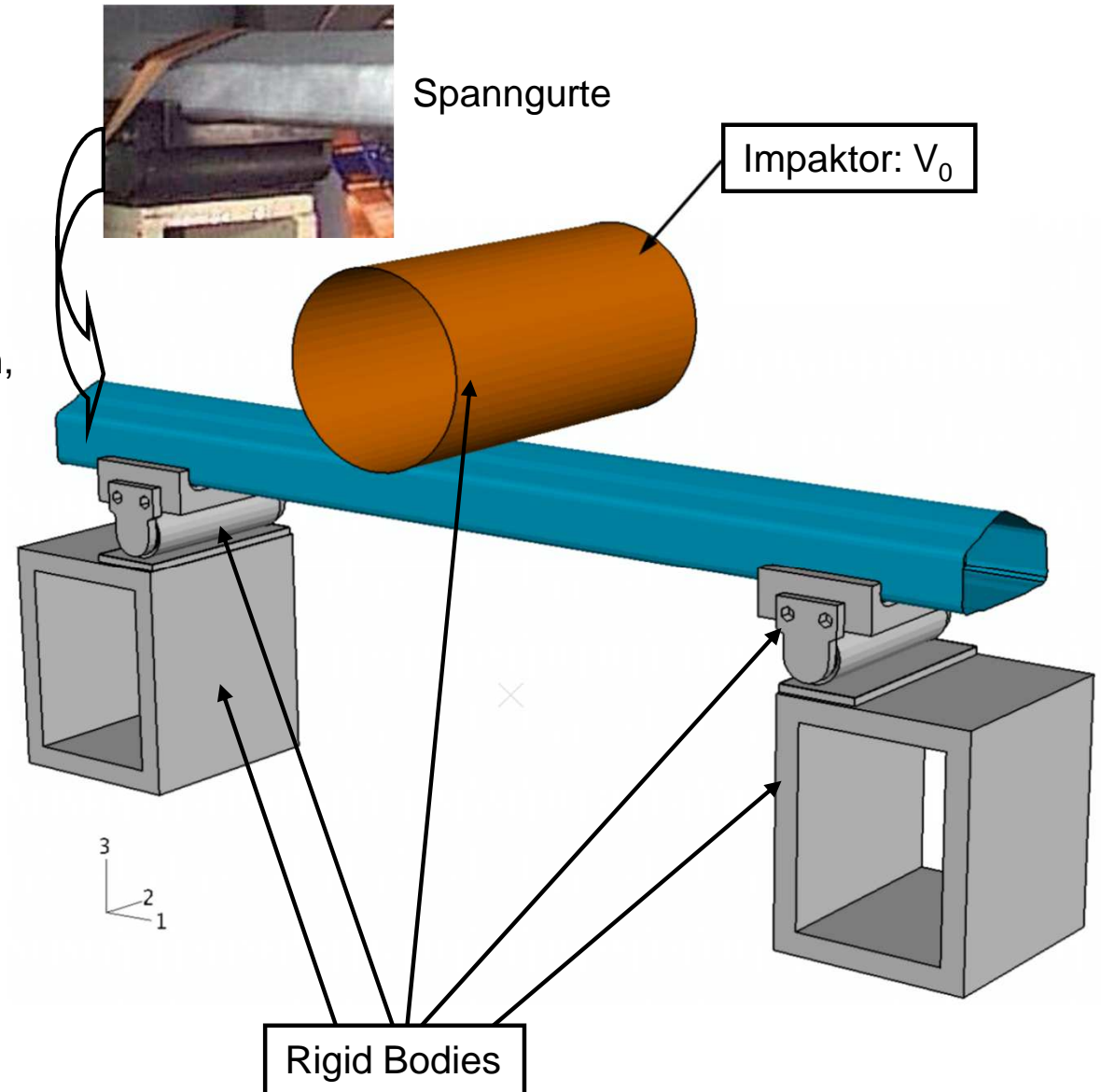
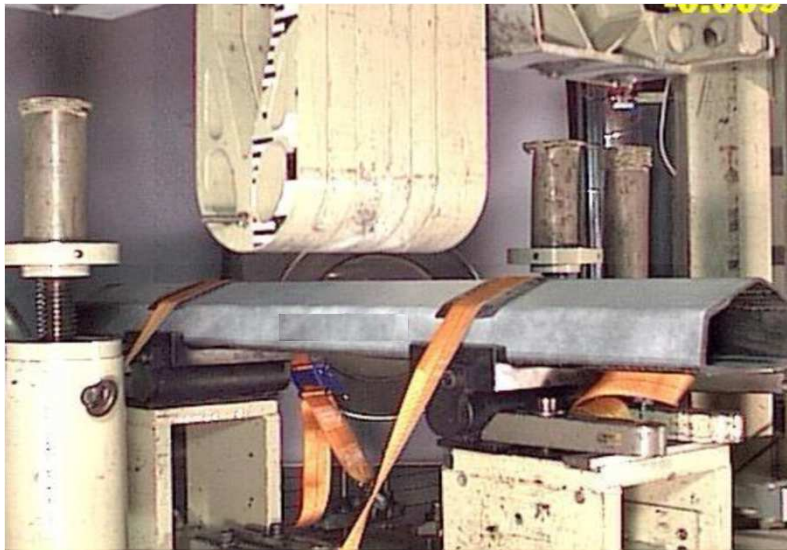

## 3-Punkt-Biegung

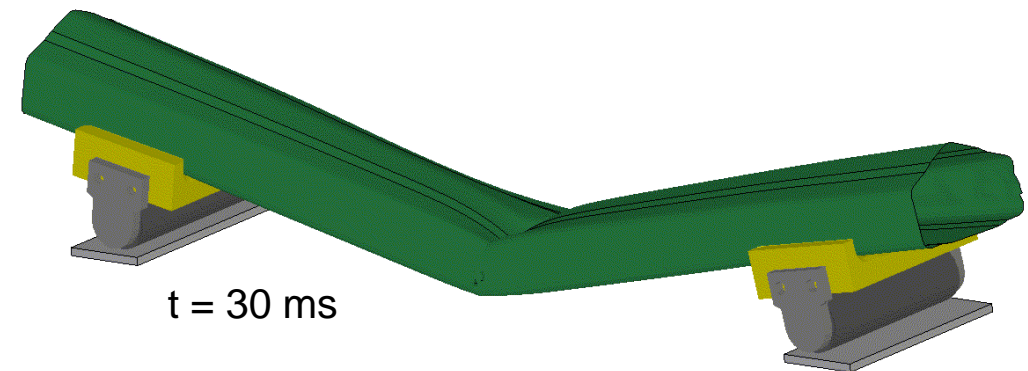
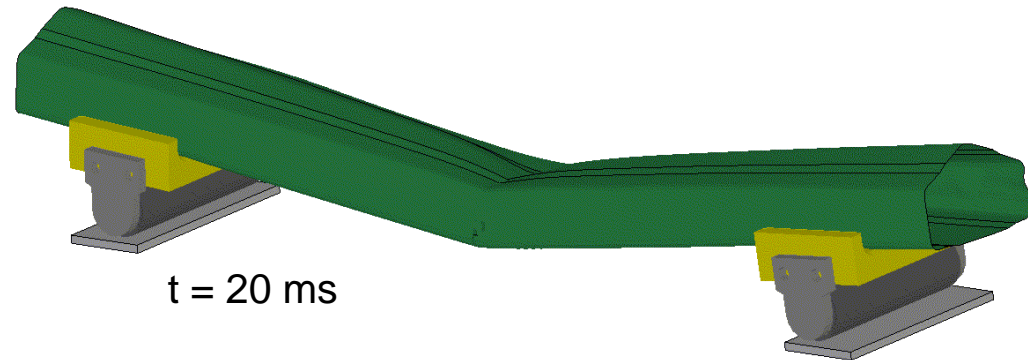
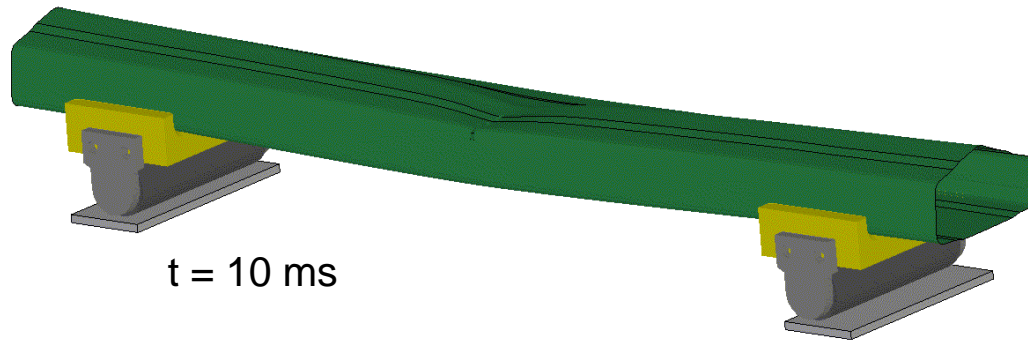

LS-DYNA mit Materialmodell  
nach P. Camanho (UserMat)

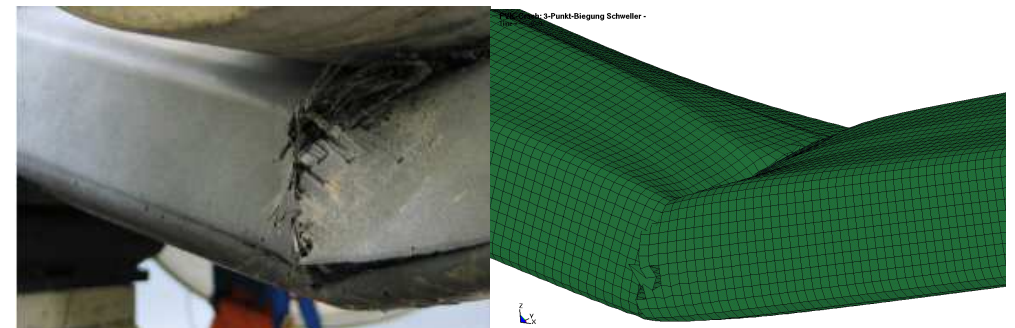
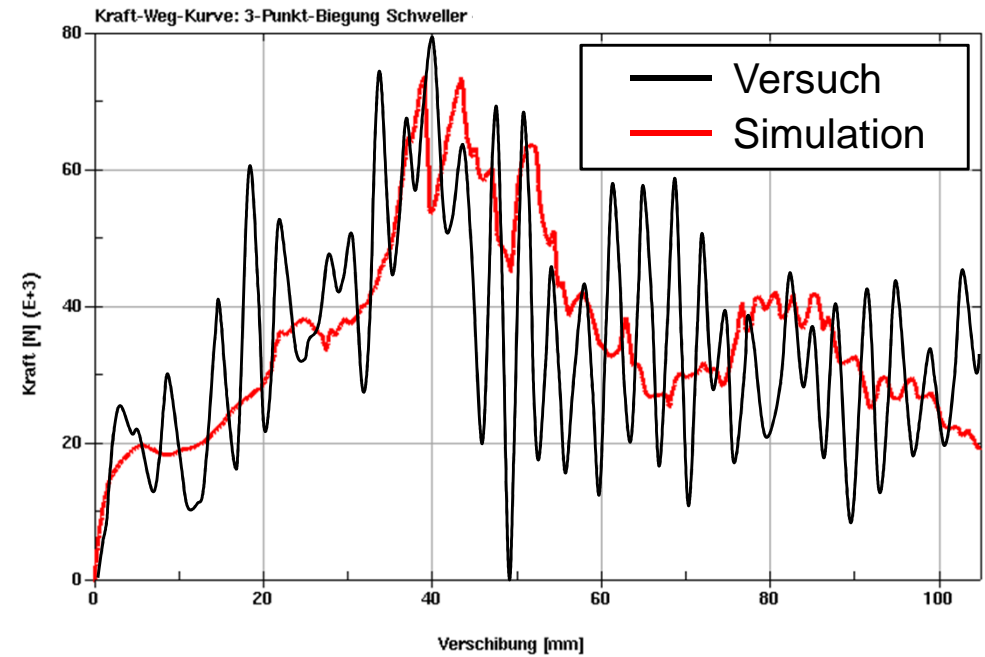

# Summary

- two continuum damage models implemented into LS-DYNA
  - advanced, coupled failure surfaces (transformation to fracture plane)
  - bi-linear/linear damage evolution laws (based on fracture toughness)
  - 1D elasto-plastic formulation for in-plane shear non-linearity
- preliminary results
  - material models able to represent general behavior, especially non-linearity in shear

available  
since R7.0

# Outlook

- many detailed numerical studies necessary for further improvements
  - comparison and parameter studies with experiments
  - different element formulations and modeling techniques (stacked shells)

# Acknowledgement

- Thank for technical support to:  
Prof. Pedro Camanho, Dr. Pere Maimí & Dr. Silvestre Pinho



**Thank you!**