

LS-DYNA Model Development of the THOR-M Crash Test Dummy

Zaifei Zhou², Ismail Maatouki¹, Paul Lemmen¹

¹Humanetics Europe GmbH, Heidelberg, Germany

²Humanetics Innovative Solutions, Inc. Plymouth, Michigan, USA

1 Standard – New Model Development

- Geometry, Mass, Assembl
- Material
- Handling
- Validation:
 - certification
 - Component/Assemblies
 - Full dummy
- QA-Robustness testing
- Customer co-operation
- Hardware development
- Release

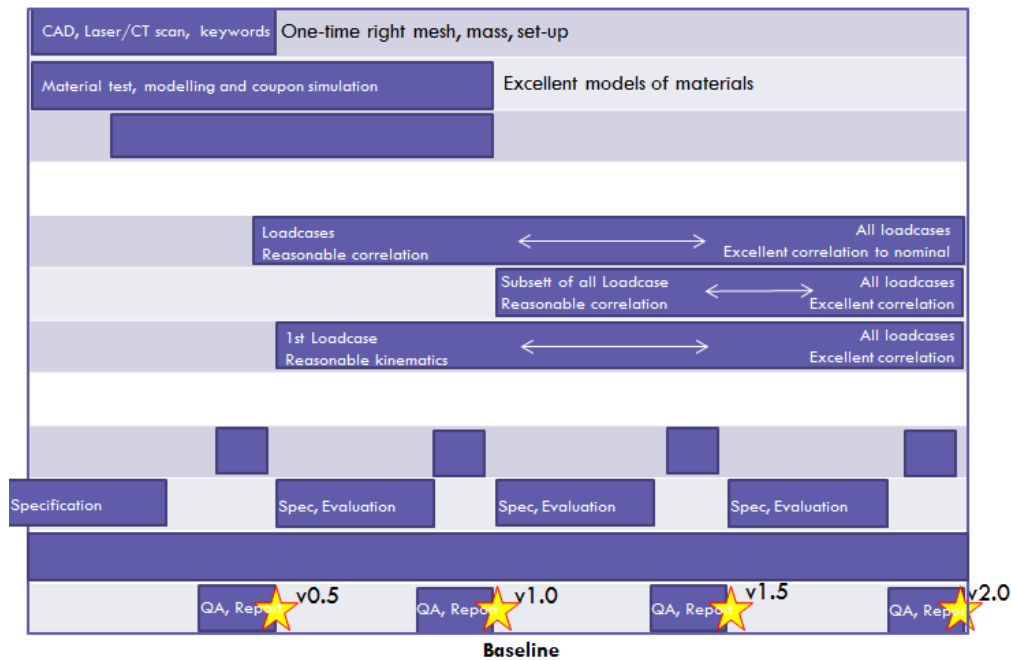

Fig. 1: Standard model development

2 Main geometry updates

2.1 Iliac Wing, H-Point Tool, Pelvis Base

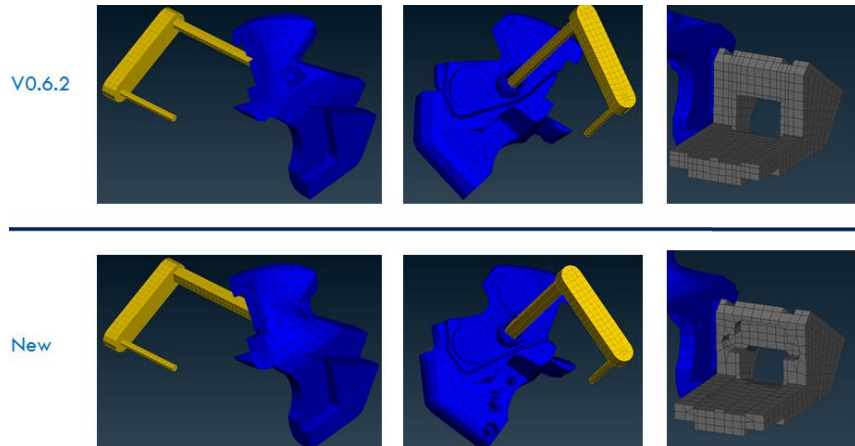

Fig.2: Main updates to the iliac wing region

2.2 Head, Neck and Shoulders

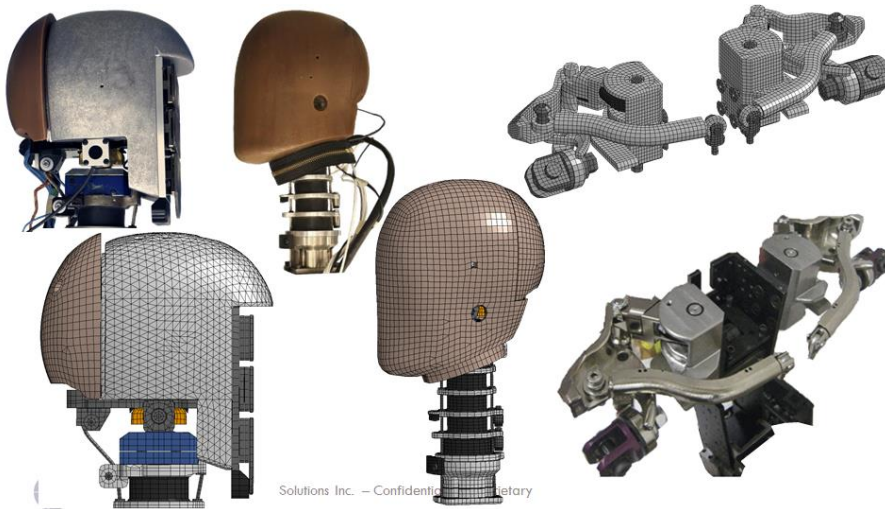

Fig.3: Main updates to the head, neck and shoulders

2.3 Thorax, Pelvis, Abdomen, Legs



Fig.4: Main updates to Thorax, Pelvis, Abdomen, Legs

3 Extended Material Test Matrix

3.1 Goal

1. Getting deeper knowledge about static and dynamic aspects of the materials' behavior.
2. Building material models with our best experience and most advanced methodologies.

3.2 Material Coupon Testing

- Following baseline material lab tests are used to define and well characterize the material card.
 - Multiple dynamic tests at different strain rates are performed to prescribe the viscosity portion of the material behavior.
 - Loading and unloading cyclic (uniaxial tension) tests are carried out for a better definition of the material behavior in its' rebound phase.

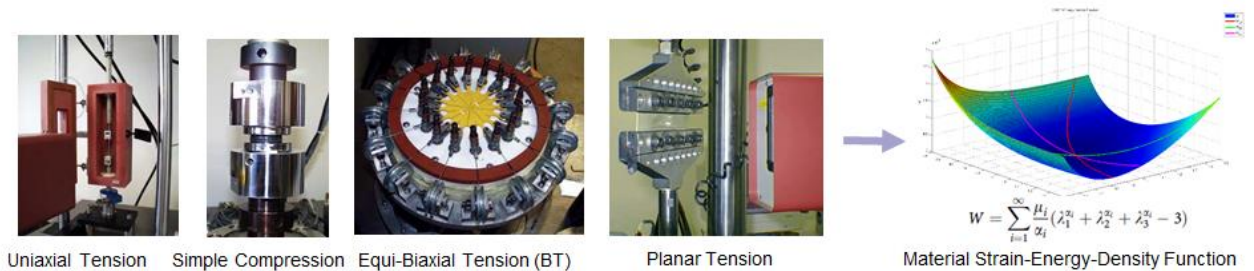

Fig.5: Material testing under different deformation modes

3.3 Material Characterization

- Mathematical functions and optimization models are designed to get and extract material parameters
- Material features at the different loading and unloading levels are built up.
- Material cards are being checked out by simulating the material coupon tests.

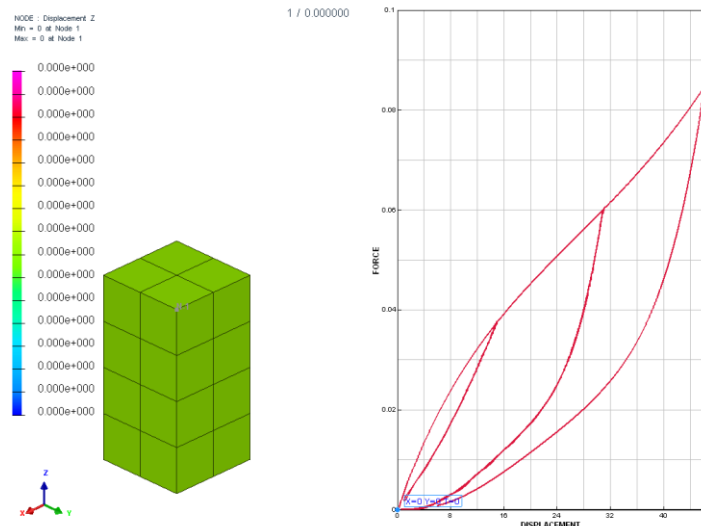

Fig.6: Example: THOR rubber material model, currently under development

3.4 Additional Material Verification and Validation

Material cards are being enhanced by making use of additional tests where more relevant deformation complexity is being introduced

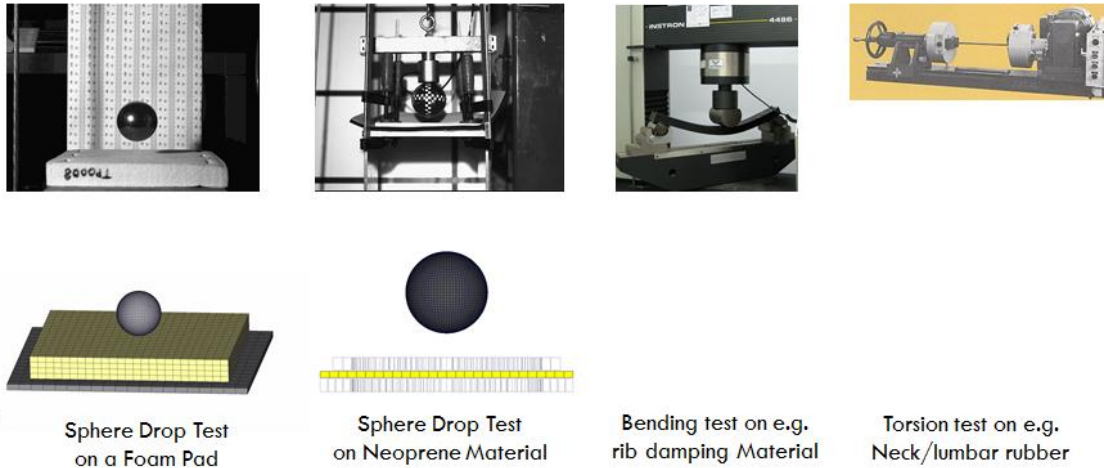

Fig.7: Examples of in-house hardware tests for material validations

3.5 Dummy Material Modeling Approach

1. Loading-state determination: All potential loading conditions of the material are determined.
2. Material model selection.
3. Experiment matrix determination: For all relevant strains & strain rates.
4. Experiment execution.
5. Material model card development
 - Material characterisation
 - Coupon test simulation
 - Additional verification and validation
 - Fine-tuning Certification, component, assembly and full dummy tests variability.
6. Material model: with excellent performance & guaranteed stability under expected and unexpected loading conditions

4 Validation Overview

- Validation of components and sub-components.
- Validation of dummy and subassembly.

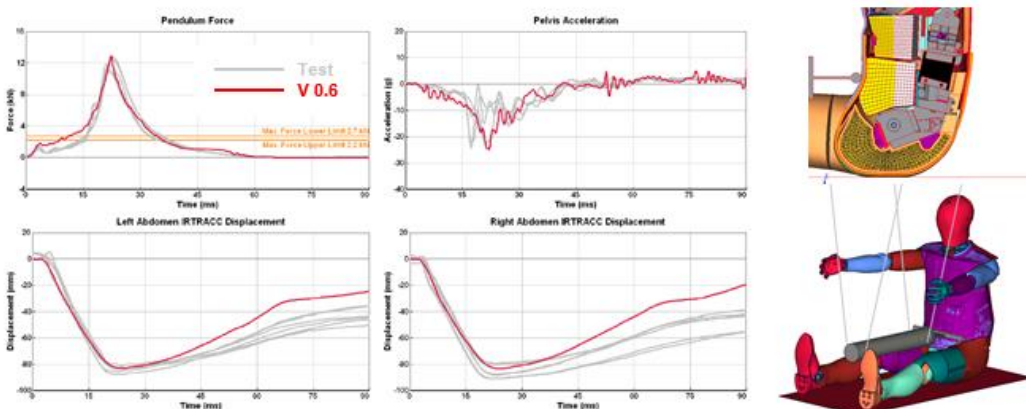

Fig.8: Full dummy certification, Lower Abdomen Pendulum Test

5 Robustness Verification Summary

The sled cases were run to verify the dummy model robustness and stability

Test	Description
Sled Belted Case 1	Rigid Seat, 3 Point Belt, Driver Side
Sled Belted Case 1 – 1.5 Times Severity	Pulse scaled by 1.5
Sled Belted Case 1 – 25 Degree Oblique	Driver and Seat rotated 25 degree
Sled Belted Case 1 – 25 Degree Oblique Passenger	Passenger and Seat rotated 25 degree
Sled Belted Case 2	Rigid Seat, 3 Point Belt, Driver Side, Knee Bolster
Sled Belted Case 2 – 1.3 Times Severity	Pulse scaled by 1.3
Sled Belted Case 2 – 25 Degree Oblique	Driver and Seat rotated 25 degree
Sled Belted Case 2 – 25 Degree Oblique Passenger	Passenger and Seat rotated 25 degree

Table 1: Robustness verification load cases

6 Sled Tests

Test data is made available by Autoliv

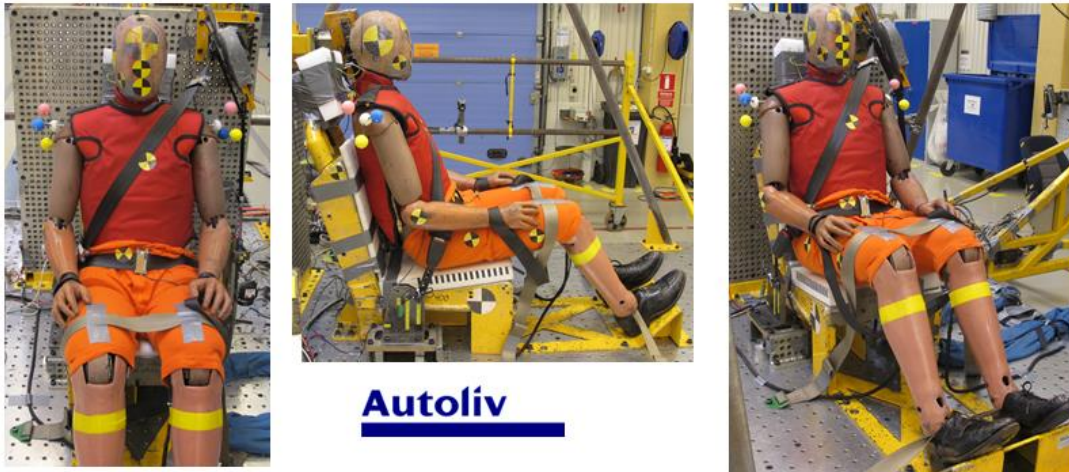

Fig.9: Example setup of the hardware sled test

The sled tests were modeled using our THOR-M model. The model could build up the kinematics of the biofidelic hardware dummy

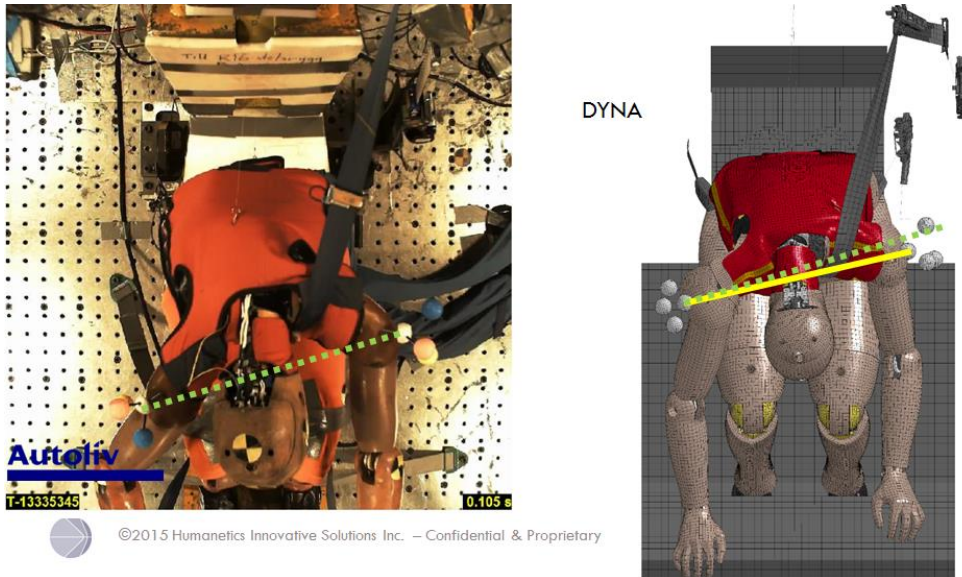

Fig.10: Comparison between THOR-M hardware & Model, maximum deformation of the biofidelic SD3 shoulder

7 2015 Plan for THOR FE Model

- There are 3 deformable segments in the THOR spine
 - Neck
 - Upper thoracic spine flex joint
 - Lumbar spine flex joint
- We would like to characterize each deformable section of spine
- The characterization will be carried out on certification and non-certification tests

7.1 Neck Validation

7.1.1 Estimation of neck deformation by analyzing head rotations from tests

- Integration of angular velocity signals
- Represents rotation relative to the ground
- Should be greater than segment-to-segment rotation

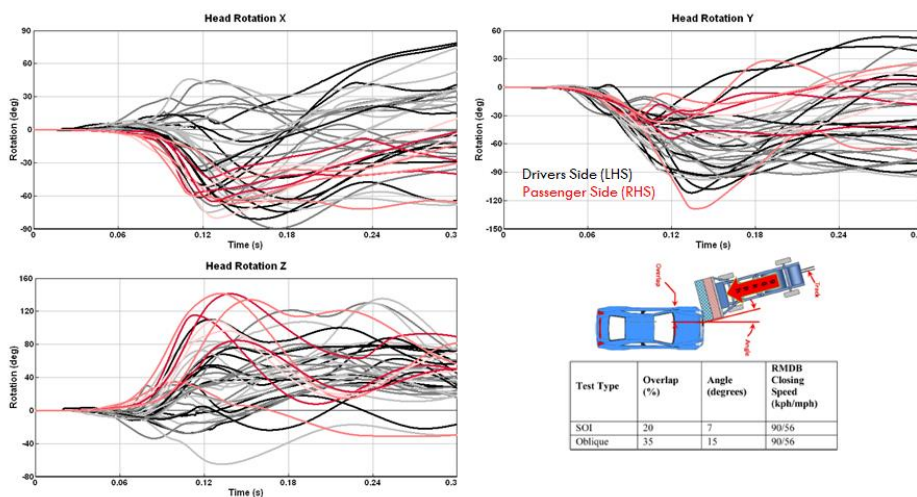

Fig.11: Estimation of head rotations from tests

7.1.2 Neck – Pure Torsion

Goal is to validate the neck under pure torsion; isolate torsion from all other loading effects.

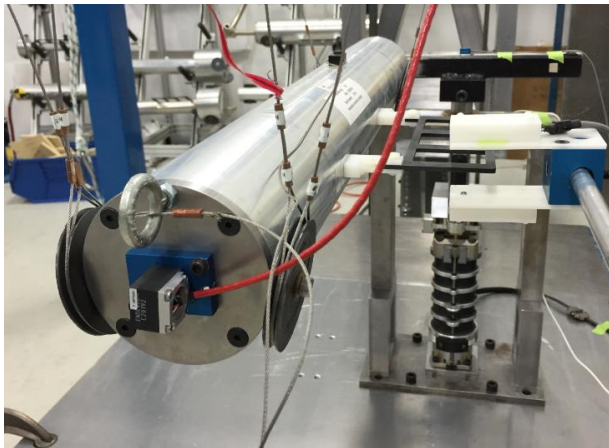

Fig.12: Hardware setup for neck pure torsion

7.1.3 Neck Testing – complex loading conditions

- Perform in-line testing on neck certification fixture (with and without cables, flexion and extension, etc.)
- Independently test pure torsion response on rotational test fixture. This can be considered as sever loading and may not take place as it is in the reality, but helps in enhance the material at the right features
- Assess multi-mode loading using mini sled with offset mass. This is the final realistic loading case the will be used to make the final validations to neck under combined complex loading conditions.

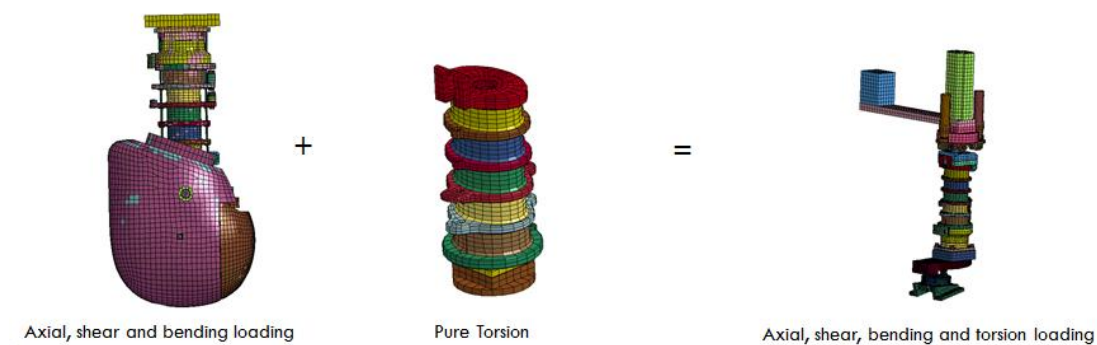

Fig.13: Complex loading conditions of the neck

7.2 Thoracic Spine & Lumbar Spine

7.2.1 Validation of the lumbar under pure bending

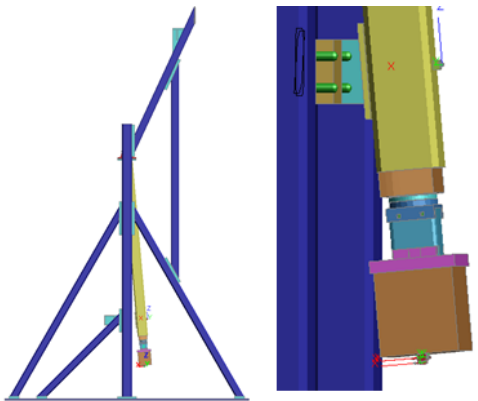

Fig.14: Hardware setup for lumbar pure bending

7.2.2 Validation of the lumbar under pure torsion

7.2.3 Validation of the lumbar under combined (complex) torsion and bending

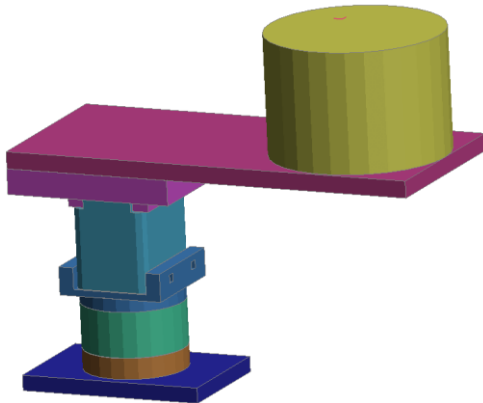

Fig.15: Test setup for lumbar pure bending, mini sled

8 Full Dummy – Advanced Sled Series

Goal is to develop sled test that represents NHTSA oblique and Small Offset Impact (SOI)

- Tests still under development
- For future FE model release



Fig.16: Advanced test setup

9 Summary

- THOR-M Hardware dummies are currently introduced to the market
 - Improved biofidelity comes with challenging repeatability and reproducibility
 - Applications in advanced new test procedures currently under development
- New version of THOR-M model is being made available
 - Exact geometry of the THOR-M hardware
 - Advanced material testing and modelling result in high reliability and stability of the model
 - Aims to ensure best model performance for enhanced prediction and representation of the current and future test procedures
- Validation effort will proceed to guarantee that this model precisely represents the nominal performance of THOR-M dummies