

# Automated Post-Processing & Report-Generation for Standard Crash & Safety Tests Simulation

Tzolas Nikolaos  
BETA CAE Systems S.A.

## Abstract

*There are an increasing number of standardized tests, for which a vehicle should comply with. All these tests, usually, require the generation of a standardized report.*

*For the generation of reports for simulated tests, after each solver run, the followed post-processing actions are always the same. Most of the tasks in the post-processing of simulation of road vehicles crash tests, involve repeated actions while, in certain cases, these actions may represent up to 90% of the total. This repetition is proven cumbersome, time-consuming and prone to errors. Therefore, the automation of the execution of those actions and the subsequent report generation is required.*

*This paper presents software tools that automatically process and create reports, for Pedestrian Safety analysis, Occupant Protection in Interior Impact (FMVSS 201U), IIHS structural ratings and Bus Rollover (ECE R66), based on LS-DYNA<sup>®</sup> results. These tools streamline the extraction of the results for the respective tests. They lead directly to reports and create overview models for supervisory evaluation in cases of a large number of simulation runs. The automation of complicated post-processing procedures in  $\mu$ ETA (mETA), the Post-Processor of BETA CAE Systems S.A., not only saves time and eliminates user's frustration but it also assures an error-free outcome.*

*Keywords: Post-processing, process automation, reporting, Pedestrian Safety, FMVSS 201U, IIHS, Bus Rollover ECE R66.*

## Introduction

New vehicles must be compliant with an increasing number of standardized tests before entering the market and the same applies on their virtual models too. Usually for these tests a standardized report is generated.

Whenever the generation of a report is required after each solver run, the post-processing procedure to be followed is each time the same. Apart from the fact that these repeated actions are proven cumbersome and time-consuming, they also make the process susceptible to errors. Therefore, the automation of the execution of those actions and the subsequent report generation is required. Being able to automate complicated procedures not only saves time and eliminates user's frustration but it also assures an error-free outcome.

In this paper the automation capabilities of  $\mu$ ETA, the post-processor of BETA CAE systems S.A. are presented.

## General Automation Capabilities

The automation requirements are facilitated by four different tools in  $\mu$ ETA:

- the user toolbars
- the session files
- the scripts
- the plug-ins

Each of these can be used alone, as well as in combination with the others so as to deliver the maximum level of automation in each case. In addition, the effortless creation of automated procedures is greatly assisted through respective editors for each of these tools.

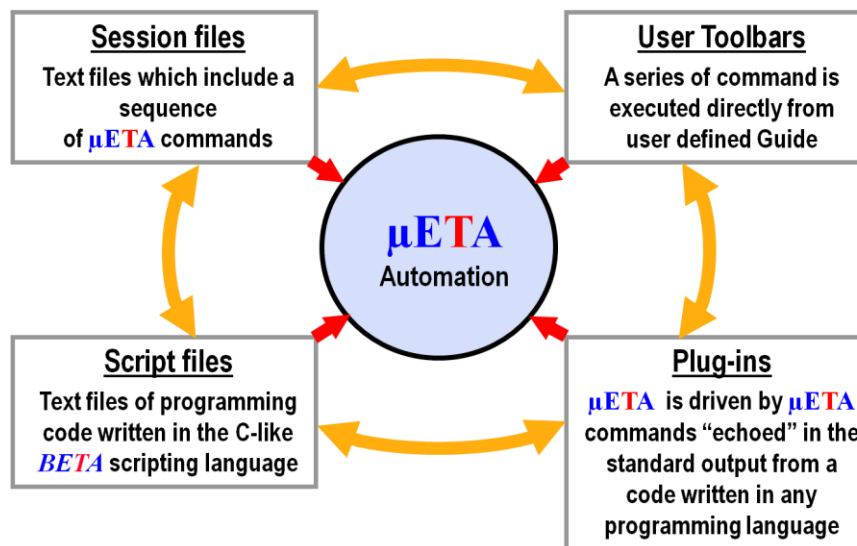

Figure 1. Automation Capabilities

The following can be achieved with these tools:

- Combination of 3d and 2d tasks
- Custom GUI: User Toolbars, GUI Library functions for scripting
- Direct access to all analysis' results through respective commands
- Fully automated reporting (html, pptx, pdf, ps)
- Automated processes can be executed before, after or between manual processes
- Created processes can be shared among different levels (company, group or user level)

Based on these automation capabilities BETA CAE systems has developed a suite of standard tools to automate the results post-processing and the creation of reports for Pedestrian Safety analysis, Occupant Protection in Interior Impact (FMVSS 201U), IIHS structural ratings and Bus Rollover (ECE R66). These are included within the standard installation of  $\mu$ ETA.

These tools streamline the extraction of the results for the respective tests. They lead directly to reports and create overview models for supervisory evaluation in cases of a large number of simulation runs.

## Pedestrian Tool

It facilitates the post-processing of the pedestrian analysis results for Headform, Legform and Upper Leg. A report that contains Time History results and videos of each Target Point and/or an overview 3d model of all the Target Points can be generated.

### Report – 2d Post-Processing

The report can be in PPTX or HTML format, or both. A Target Points text file is used for the creation of the report. This is an ASCII file with all the data for each target point. It is output by ANSA at the automatic positioning of the head/leg for all the target points (version v13.1.0 and after). After the definition of all the input data, the results – Target Points – that will be processed can be selected from a list.

The standard Time History report for the selected analysis is:

- Headform: One summary table with all the HIC values of the selected Target Points will be created in the first slide. For each Target Point, images of 2d-plots will be added that will show the Magnitude of Acceleration curve, the HIC curve, and the X / Y / Z Displacement and Contact Force components curves.
- Legform: One summary table with all the Acceleration, Bending Angle and Shear Displacement values of the selected Target Points will be created in the first slide. For each Target Point one slide with Acceleration, Bending Angle and Shear Displacement values over Time and over Intrusion will be generated.
- Upper Leg: One summary table with all the Upper, Lower and Total Force values and all the Upper, Lower and Mid Moment values of the selected Target Points will be created in the first slide. For each Target Point one slide with the Upper, Lower and Total Force curves and the Upper, Lower and Mid Moment curves over Time and over Intrusion will be created.

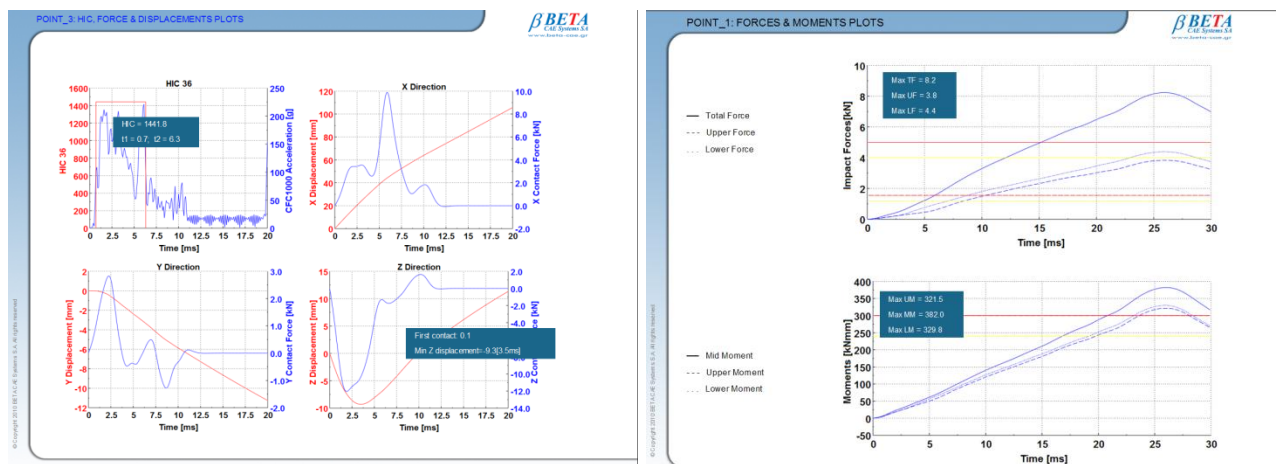

Figure 2. Examples of standard 2d post-processing reports for Headform and Upper Leg

## Report – 3d Post-Processing

Animations of each Target Point can be added in the report for Headform, Legform and Upper Leg. Apart from the animations when 3d post-processing is selected one state is created which shows the maximum deformations, which come from the processed Target Points, on user defined groups of parts (bonnet, bumper, etc.).

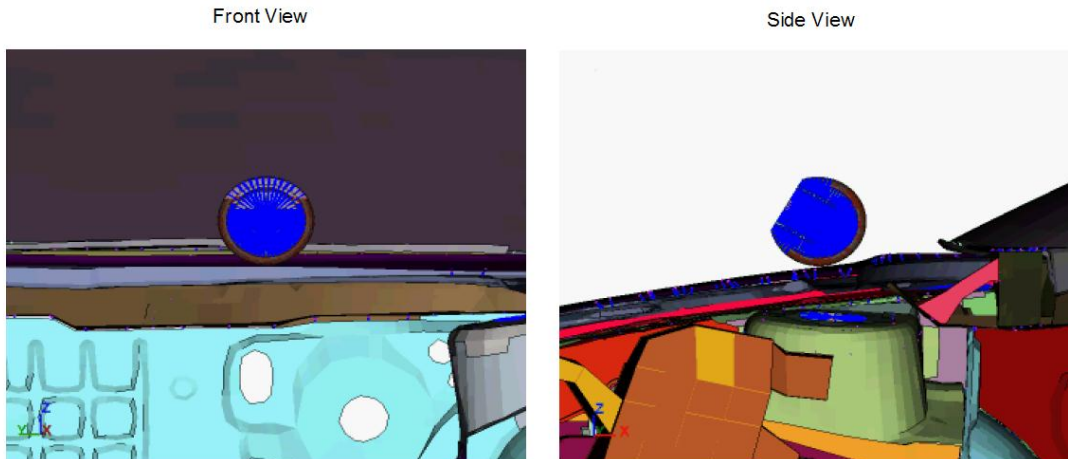

Figure 3. Example of videos in the Report (Headform)

Apart from the default report that is created, the tool provides options for customization:

- A session of commands can be recorded, parameterized and used within the tool in order to add other than the standard results/videos in the report
- Sessions can be used for customization of the report's slides, of the 2d plots and of the videos that are saved
- HIC Limits and HIC Time interval (Headform)
- Acceleration, Bending Angle and Shear Displacement Limits (Legform)
- Total, Upper, Lower Force and Lower, Mid, Upper Moment Limits (Upper Leg)

## Results Overview

An overview of all the results (Target Points) can be created on a single 3d model for supervisory evaluation.

Two types of overview models can be created for Headform. A "No raster" model and a "Raster EU Phase 1/2". This overview model can contain:

- All HIC values mapped with a user defined radius on the bonnet
- All HIC values presented in circular annotations on the bonnet
- EuroNCAP Percent Score calculation, displayed in an annotation
- HIC values interpolated either on the entire bonnet or on the raster area. A new model is created that corresponds to the projected impacted area of the bonnet at  $Z = 0$ , with the interpolated HIC values
- Calculation of the percentage of the visible area above a specified threshold HIC value
- Calculation of the HIC value that corresponds to a specified percentage of area

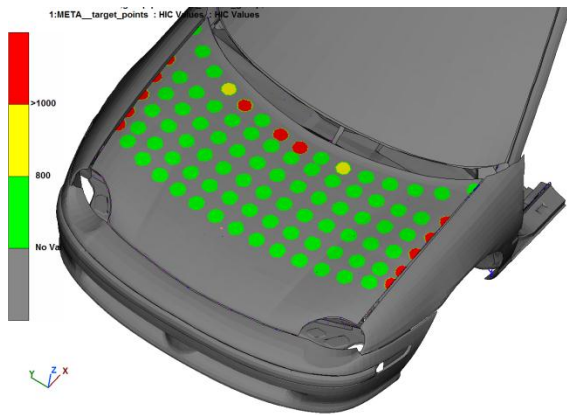

Picture 4. HIC values mapped on bonnet

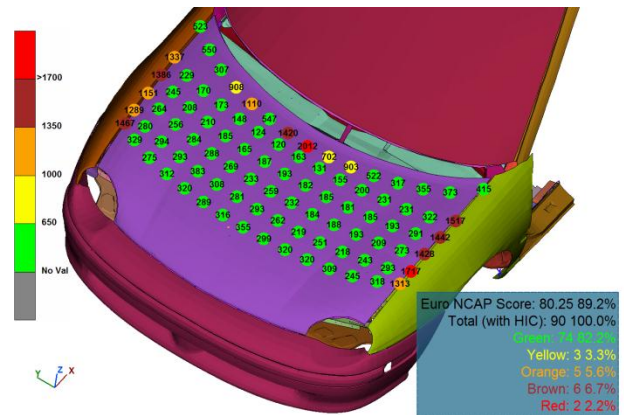

Picture 5. Annotations with HIC values and EuroNCAP Score calculation

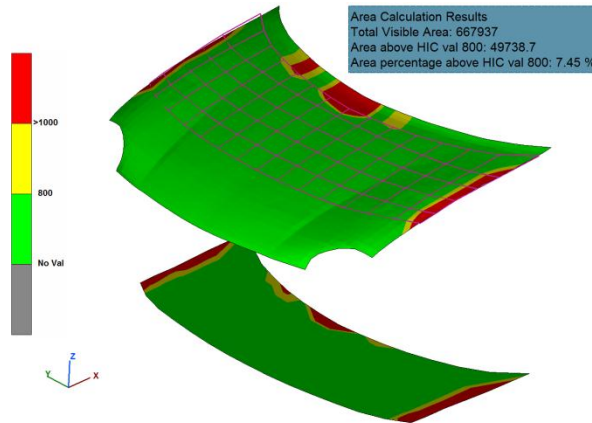

Picture 6. HIC values interpolated on the bonnet. Raster area projected on Z = 0. Area calculation for HIC values above a threshold.

The overview model for Legform can contain:

- Annotations that display the name, the Y coordinate and the Acceleration, Bending Angle and Shear Displacement values of each position
- 2d plots that show the Acceleration, Bending Angle and Shear Displacement values along the length of the bumper



Picture 7. Legform overview using Annotations

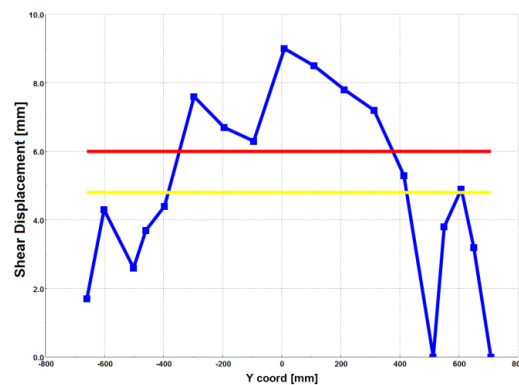

Picture 8. Legform overview using 2d plots

The overview model for Upper Leg can contain:

- Annotations that display the name, the Y coordinate and the Upper, Lower and Total Force values and the Upper, Lower and Mid Moment values of each position
- 2d plots that show the Upper, Lower and Total Force values and the Upper, Lower and Mid Moment values along the length of the bumper

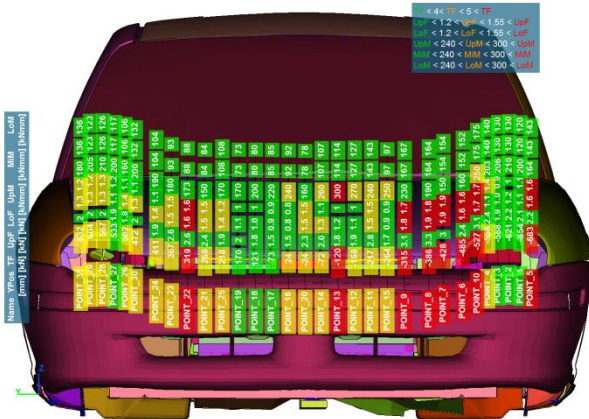

Picture 9. Upper Leg overview using Annotations

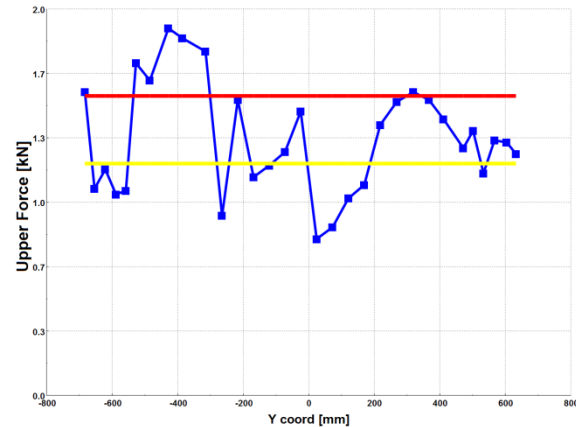

Picture 10. Upper Leg overview using 2d plots

What can be customized in overview models is:

- HIC Limits (Headform)
- Annotations text (Headform)
- Where the HIC values will be interpolated and which surface will be projected to  $Z = 0$  (Headform)
- Acceleration, Bending Angle and Shear Displacement Limits (Legform)
- Total, Upper, Lower Force and Lower, Mid, Upper Moment Limits (Upper Leg)

## FMVSS 201U Tool

This tool supports the post-processing of the FMVSS 201U analysis results. The results of each Target Point can be post-processed individually and a PPTX report is generated. An overview of all results on a single 3d model as annotations and lines can also be created.

### 2d/3d Post-Processing - Report

The report is in PPTX format. A Target Points text file is used for its generation. This is an ASCII file with all the data for each target point that it is output by ANSA. The results – Target Points – that will be processed can be selected from a list.

With the individually 2d / 3d post-processing of the selected Target Points the CAE analyst can obtain:

- A summary table with all the HIC values of the selected Target Points in the first slide of the report

- 2d plots for each Target Point with the Resultant Acceleration of Head over Time and over X Displacement of the Head, added in the report
- All the Resultant Acceleration of Head over Time and over X Displacement of the Head curves in one 2d plot for Comparison, added in the report
- Videos of the hits added in the report. The elements that will be shown in the video are the ones lying within a user defined radius measured from the Head. The default view of the model for the video can also be specified
- 3d Comparison of Target Points using cutting planes
- Combined 2d and 3d post-processing added in the report

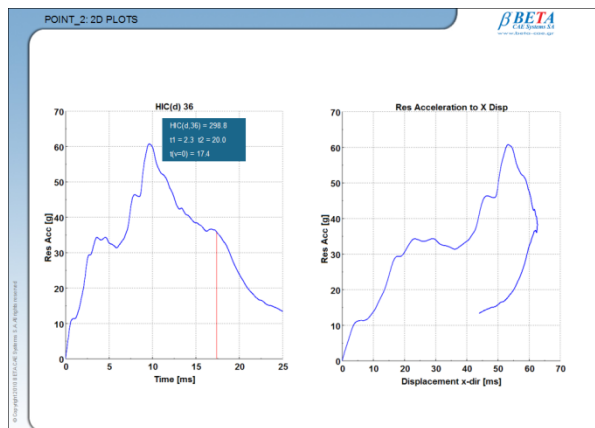

Picture 11. Resultant Acceleration over Time and over X Displacement in the report



Picture 12. Videos of the hit in the report

Similarly to Pedestrian tool, the 2d / 3d post-processing of the Target Points can be customized:

- A session with commands can be recorded, parameterized and used in the tool in order to add the desired results/videos in the report
- Sessions can be used for customization of the report's slides, of the 2d plots and of the videos that are saved
- HIC Limits and HIC Time interval

## Results Overview

An overview of all the results (Target Points) can be created on a single 3d model.

The overview model can contain:

- All HIC values presented in circular annotations attached on the Target Points - The annotations are colored according to HIC value that they display
- Lines that present the direction of each hit. The HIC value of the Target Point is presented in an annotation
- The Max and Min HIC values of a group of Target Points presented in an annotation attached on the Target Point

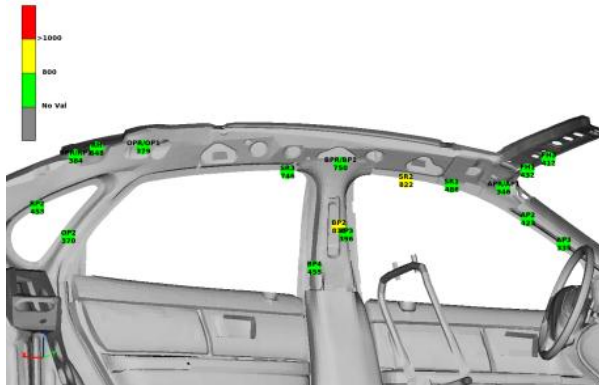

Picture 13. Circular annotations with HIC values on Target Points

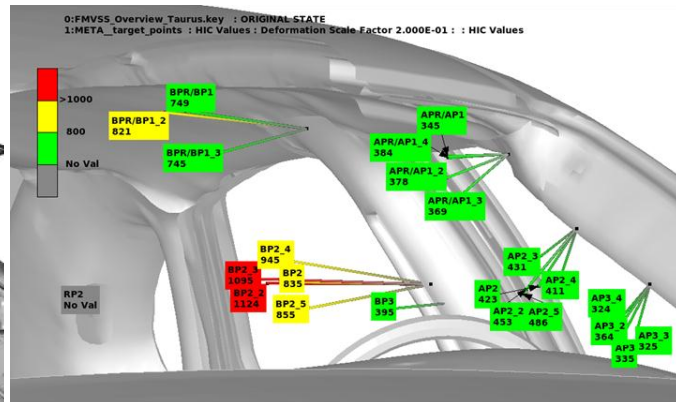

Picture 14. Lines presenting each hit's trajectory. HIC values displayed in annotations

What can be customized in overview model is:

- HIC Limits
- HIC Time Interval that will be used
- Annotations text
- Drawing of Max of Positions and of Target Points
- Solid lines and Expansion Factor of these lines

## IIHS Tool

This tool facilitates the post-processing of IIHS structural results. Intrusion plots can be created for Frontal and Side Impact as well as the Strength to Weight Ratio plot for Roof Crash. These plots can be added in the report automatically. Cutting planes can be easily created on different coordinates for better visualization of the results on the models. Apart from processing each model separately, summary tables with all the intrusion and Strength to Weight Ratio results can be created for many models.

### Front Impact

The amount of intrusion into the occupant compartment after the crash is measured. Measurements are taken at nine places around the driver's seat. The Intrusion Plot can be created either from 3d results or from Time History results. If 3d results are selected then all the positions (nodes), for which intrusion will be measured, can be selected (pick) from the model. If 2d results are selected then these nodes can be selected from lists.

For the five standard Toeboard positions that are required from the regulation, more than one node can be specified initially. The tool will find the node with the maximum intrusion among the selected and will add its value in the Intrusion Plot.

Apart from these five standard Toeboard positions, the intrusion of more positions on the Toeboard can be added in the Intrusion Plot. These extra positions can be easily defined through the interface of the tool. The displacement component that will be taken into account for the intrusion calculation can be selected for these positions.



Optionally the intrusion values can be scaled. This can be done either globally (the same scale factor for all intrusions) or for each position separately.

In the Intrusion Plot the scaled values are added by default. There is the option to add the maximum intrusion values (not scaled) and the intrusion values of the final time step. One more 2d plot is created with the Intrusion values of the selected positions over Time.

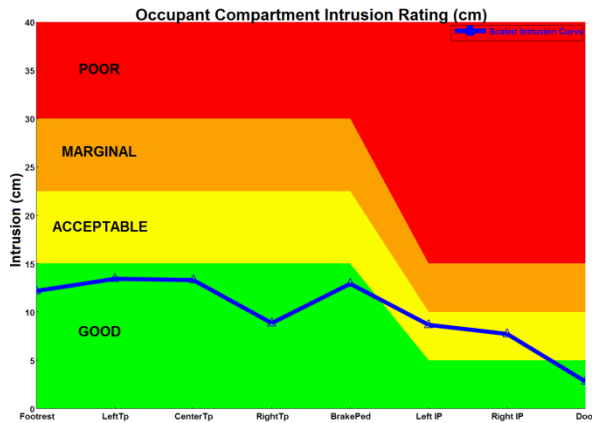

Picture 15. Frontal Impact Intrusion Plot

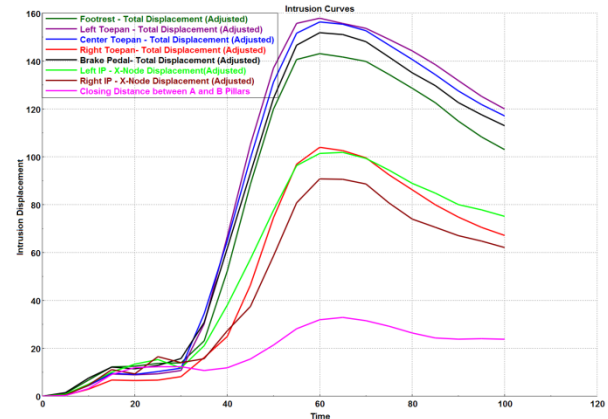

Picture 16. Intrusion values over Time

Data for each position can also be exported in ASCII files. The coordinates and displacements of position nodes for every time step will be saved in this file. If more than one nodes are selected for a position then the coordinates and displacements of the node that had the maximum intrusion will be saved in the file. For the Extra Toeboard positions a separate file is created.

## Side Impact

The amount of intrusion into the occupant compartment around the B-pillar is measured. 3d results are used for the creation of the Intrusion Plot.

Two nodes are used on the B-pillar in order to specify a section of which the intrusion will be measured. Optionally a series of nodes on the B-pillar can be specified in order to measure the intrusion of these specific nodes.

Two 2d plots are created. The first 2d plot shows the maximum intrusion of the B-pillar's section among all time steps of the analysis as well as its final intrusion. The final and the minimum distance from driver's seat centerline are measured. Information about the node Id, at which time and at which Z coordinate, this maximum intrusion occurs, is presented in an annotation.

The second 2d plot shows the deformations of the B-pillar section at each time step. The maximum deformation (maximum Intrusion) and the final deformation are highlighted.

In the 3d window the B-pillar's section is animated. A color model is added in order to show during this animation the distance from the B-pillar to driver's seat centerline.

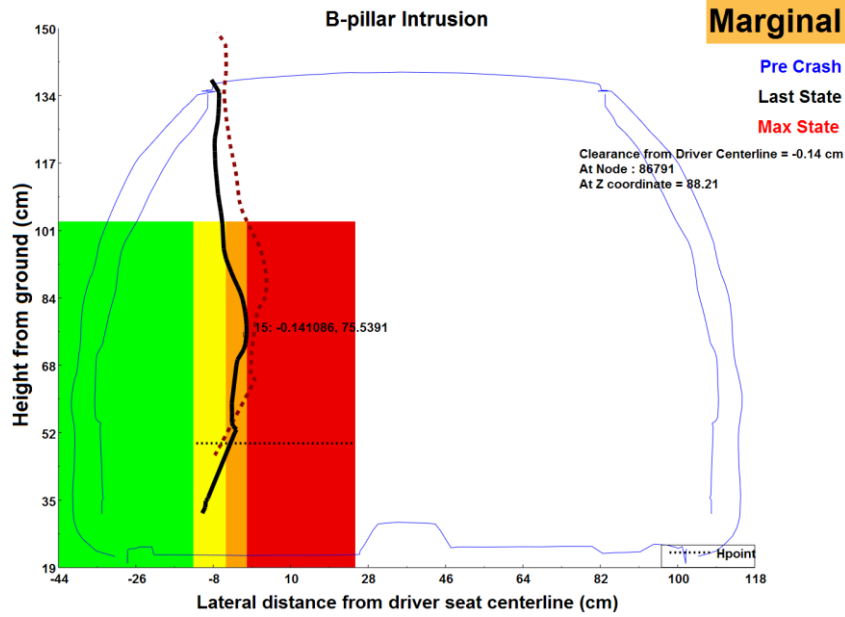

Picture 17. B-pillar Intrusion Plot

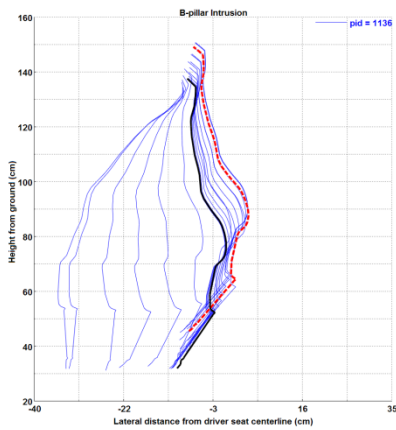

Picture 18. B-pillar's deformations at each state

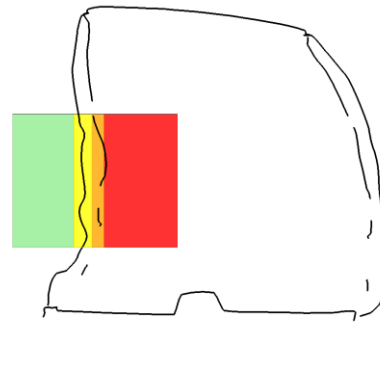

Picture 19. Animation of B-pillar's cut section

## Roof Crash

The Strength to Weight Ratio plot can be automatically created from this part of the tool. For the creation of this plot Time History results are used.

Two 2d plots are created. The first is the Strength to Weight Ratio plot, which shows the Strength to Weight ratio curve for the 5 first inches of intrusion. The other plot shows the Force between the vehicle and the plate, over Intrusion and over Time.

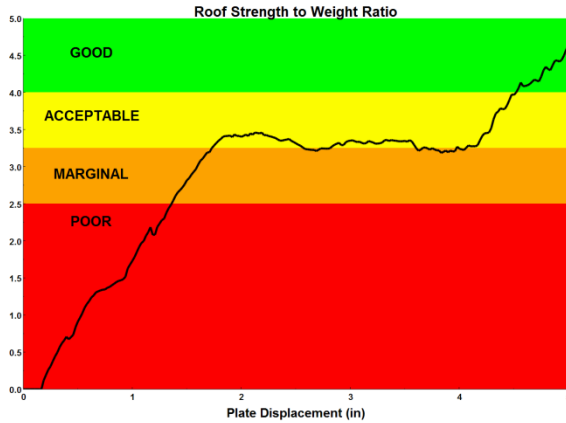

Picture 20. Strength to Weight Ratio plot

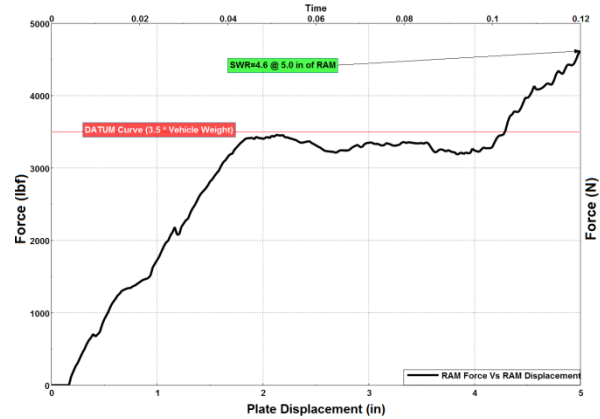

Picture 21. Force to Displacement / Time

All user input that is needed for the tool (Front Impact, Side Impact and Roof Crash) to work can be saved in ASCII files (configuration files) from the tool. These files can be read in the tool in order to populate the input data to the respective fields.

Using this functionality the tool can be used within an optimization cycle. There is the option to create annotations with the Intrusion values (Front and Side Impact) or the Strength to Weight Ratio value (Roof crash). These annotations will be used by the OptimizerSetup tool (another tool included within the standard installation of  $\mu$ ETA) for the Design Responses' definition. In each iteration,  $\mu$ ETA is called by the optimizer (e.g. LS-OPT®) and a session file that is saved from the OptimizerSetup tool is executed. With this session file the Configuration file that was saved from the IIHS tool is read and all the input data populate in the tool's fields. The tool creates the annotations with the Intrusion values or the Strength to Weight Ratio value that are passed to the optimizer.

Configuration files are also used in order for the tool to process many models and to create summary tables with the Intrusion values or the Strength to Weight Ratio values.

IIHS FRONT STRUCTURAL ASSESSMENT SUMMARY								
Iteration	Footrest	LeftTp	CenterTp	RightTp	BrakePed	LeftIP	RightIP	Door
Run 01	124.85	135.01	185.4	115.32	198.58	201.69	173.95	31.76
Run 02	137.17	157.2	202.23	122.96	211.28	211.32	173.93	35.29
Run 03	134.67	137.42	189.16	138.79	205.4	216.48	185.76	36.07
Run 04	159.23	122.19	162.47	110.3	205.4	255.96	168.42	82.66
Run 05	157.83	130.25	177.56	106.68	213.35	254.33	164.69	66.97
Run 06	179.41	142.86	184.34	141.74	224.86	251.3	176.07	77.46
Run 07	168.82	135.52	179.84	130.2	221.71	267.63	176.4	79.3
Run 08	152.52	122.3	166.74	87.54	205.7	252.32	180.24	59.64
Run 09	134.29	147.83	194.16	102.59	208.17	209.67	170.36	32.05
Run 10	131.09	155.3	204.06	121.28	213.51	198.68	158.75	31.22

Picture 22. Example of Front Impact summary spreadsheet table

## BusRollover Tool

With this tool the intrusion of the vehicle's superstructure to the Survival Space (ECE R66 regulation) can be measured.

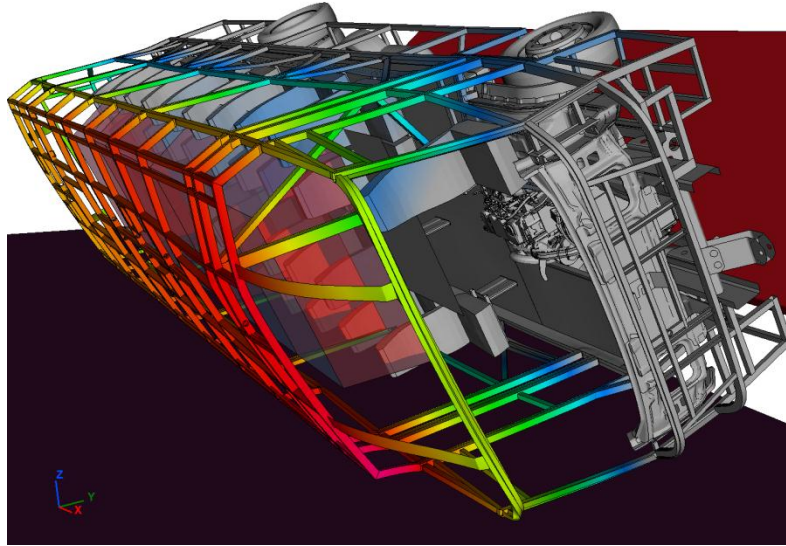

Picture 23. Bus Roll Over

Sections are defined along the vehicle's length. For each section one upper and one lower Survival Space node have to be defined. The parts that are opposite these nodes are defined too, using PID(s), group of elements or 3 nodes that define a surface, in case the Survival Space section is opposite to a window.

After the definition of the sections, the tool creates automatically 2d plots that show the minimum distance between the Survival Space and the vehicle's superstructure at each section.

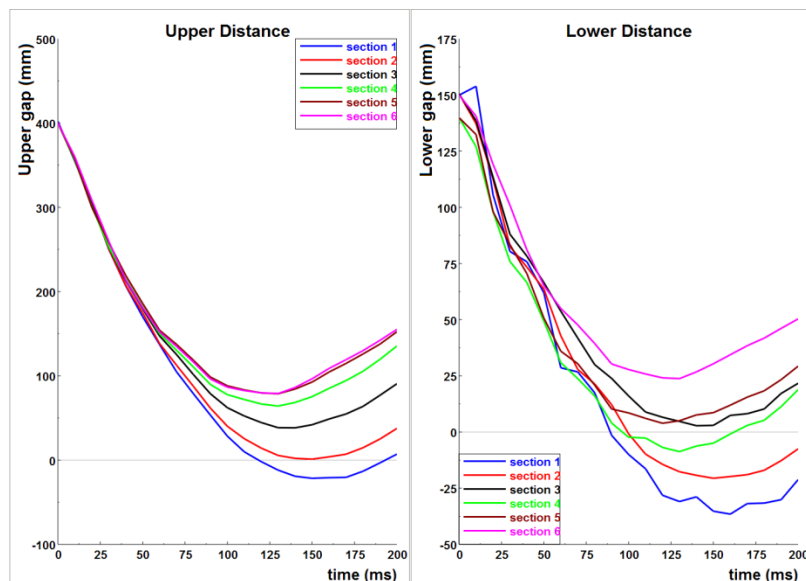

Picture 24. Intrusion Plots

The intrusion at each section of the Survival Space can be viewed using cutting planes.

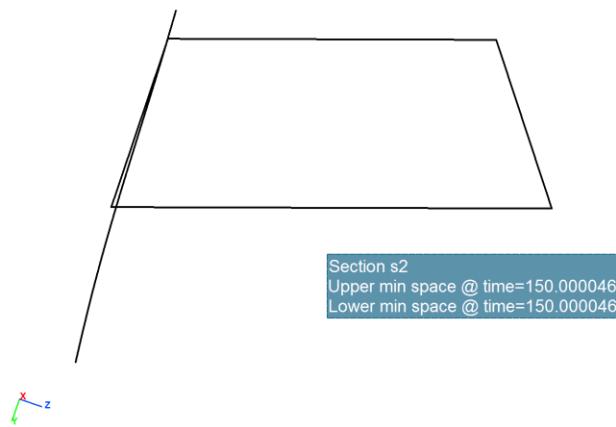

Picture 25. Intrusion of vehicle to Survival Space

The definition of the sections can be saved in ASCII files (Configuration files) from the tool and can be used again from the tool in order to create sections automatically.

## Conclusion

Using the tools that  $\mu$ ETA offers for the automated post-processing of standardized Crash & Safety tests simulation, CAE engineers save valuable time for their work. Not only simple repeated actions can be avoided but also very complicated procedures can be automated in order to have the same outcome for every model - Target Point that is processed. Complicated procedures can lead to errors so the automation of these procedures assures that the outcome (report) will be error-free. Apart from saving time and having error-free reports, automation helps to process and compare more models - Target Points at the same time.

## References

1. Pavlidis V., I Siskos D., "Current Trends in Post-Processing of FEA Results in the Automotive Industry"
2.  $\mu$ ETA version 6.8.0 Pedestrian Toolbar, BETA CAE Systems S.A.
3.  $\mu$ ETA version 6.8.0 FMVSS 201U Toolbar, BETA CAE Systems S.A.
4.  $\mu$ ETA version 6.8.0 IIHS Toolbar, BETA CAE Systems S.A.
5.  $\mu$ ETA version 6.8.0 Bus Rollover Toolbar, BETA CAE Systems S.A.

